

UMBROSA

UNIQUE SHADE DESIGN

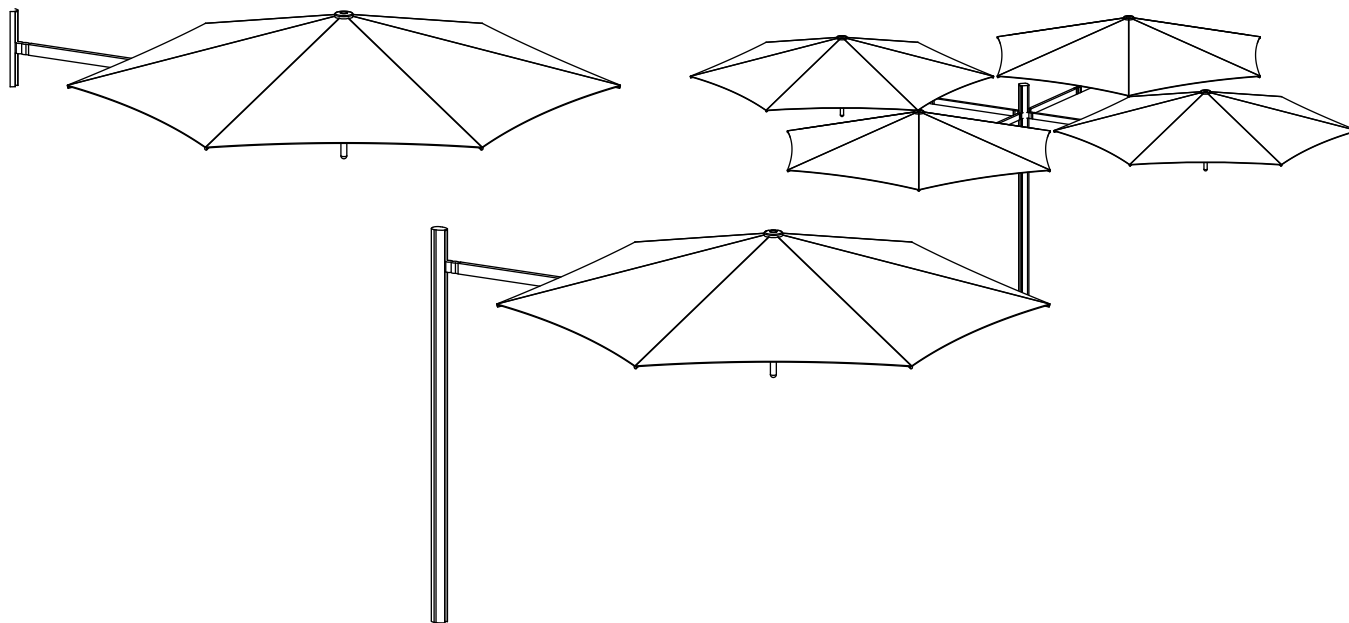

PARAFLEX CLASSIC / EVOLUTION / MONO POLE / MULTI POLE

UMBROSA

UNIQUE SHADE DESIGN

- ENG** Congratulations with your purchase! Please completely read and follow all the instructions.
- NL** Proficiat met uw aankoop! Gelieve alle instructies te lezen en op te volgen.
- FR** Félicitations avec votre achat. Lisez svp les instructions complètes.
- DE** Herzlichen Glückwunsch zu Ihrem Kauf! Bitte vollständig lesen und befolgen Sie alle Anweisungen.
- ES** Felicidades con su compra! Por favor lea y siga todas las instrucciones.
- IT** Congratulazioni con il Vs. acquisto! Vi preghiamo di leggere bene le istruzioni e di seguirne scrupolosamente le indicazioni.

UMBROSA.COM

BEFORE YOU START

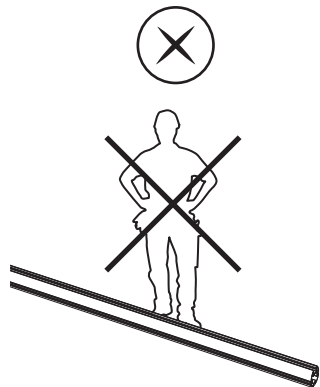
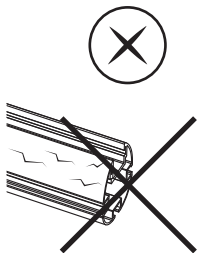
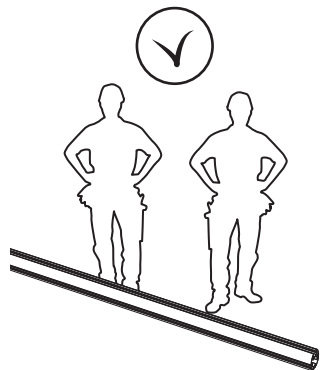
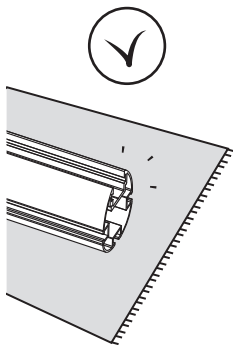

INDEX

BASE AND ANCHOR OPTIONS

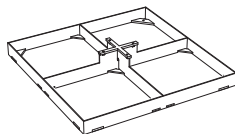

p5

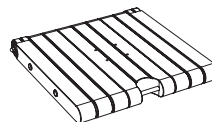

p9

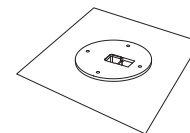

p13

PARAFLEX OPTIONS



PARAFLEX WALL MOUNT p17

PARAFLEX EVOLUTION HOLDER p20

PARAFLEX CLASSIC HOLDER p20

PARAFLEX SINGLE POLE p24

PARAFLEX MULTI POLE p26

PARAFLEX 4+1 p28

PARAFLEX WALL BRACKET p30

PARAFLEX DUOFLEX HINGE p32

PARAFLEX CANOPY p34



USER INSTRUCTIONS p36



TIPS AND MAINTENANCE p42



WARRANTY
AND SPARE PARTS

p45

INSTALLATION DIMENSIONS

POLE - BASE PLATE

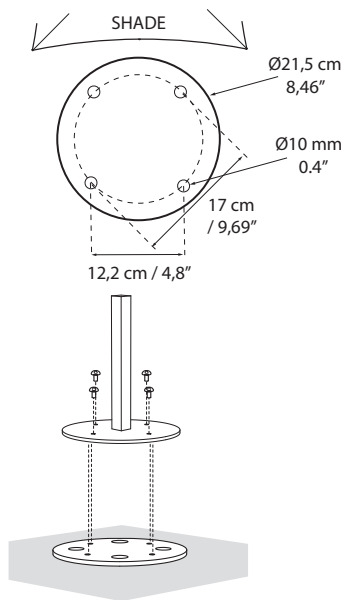

SINGLE POLE (220 cm)

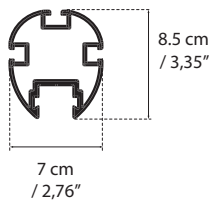

POLE - CONCRETE ANCHOR

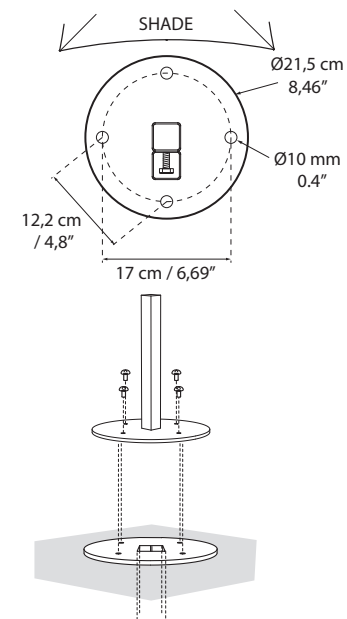

MULTI POLE (230 cm)

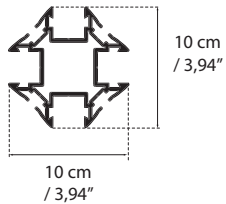

WALL

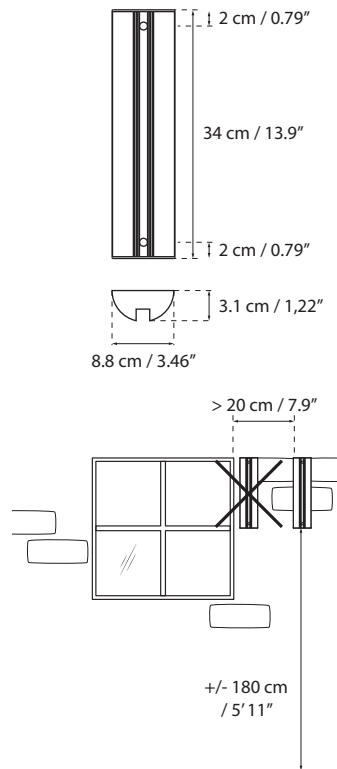

HOLDER

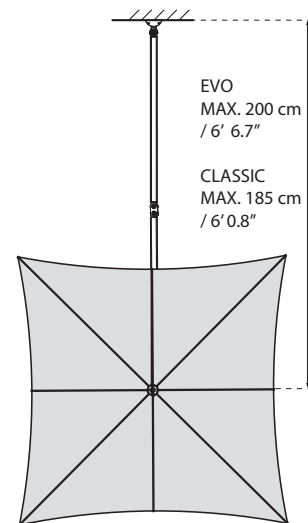

TILE BASE INSTALLATION

UMFIXTILMOBG0000

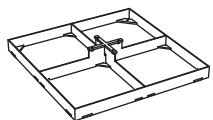
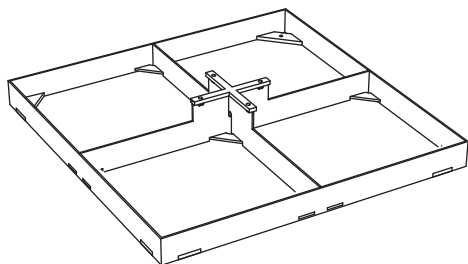

MAFIXTILMOBG0000



MABOLI0490

4x



MACOMU020B

4x

OPTIONS

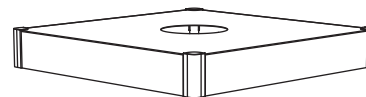

UMFIXTOPMOBA0000

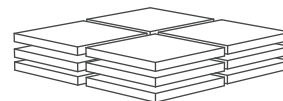

UMFIXTILES120000



UMBASM80FL017EXT

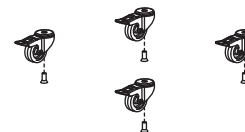

UMBASEWHEELH00

TILE BASE INSTALLATION

1

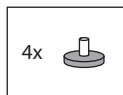

UMBROSA.COM

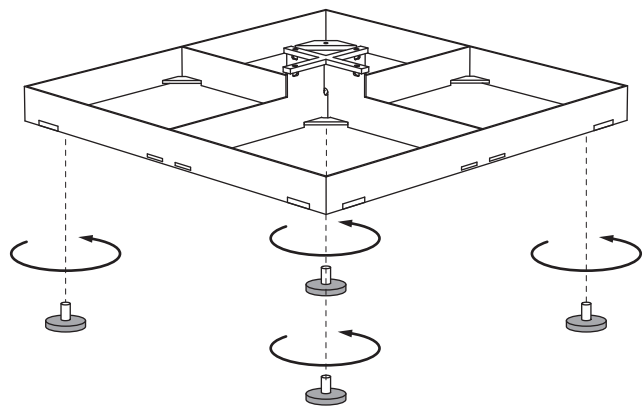
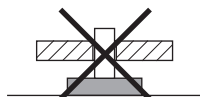
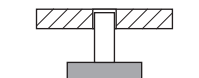

OR OPTION : UMBASM80FL00EXT

1'

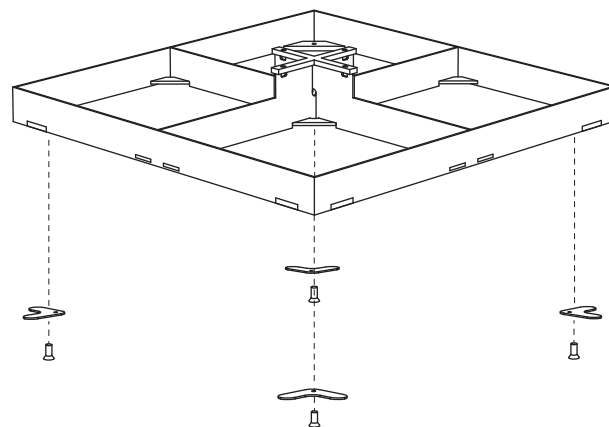
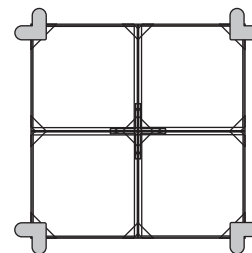
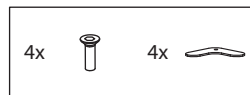

TILE BASE INSTALLATION

OR OPTION : UMBASEWHEELH00

1"

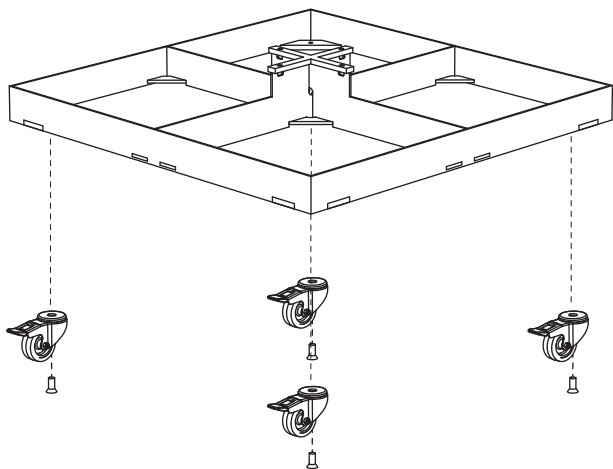
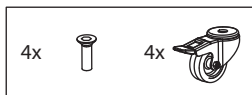

UMFIXTILES120000

2

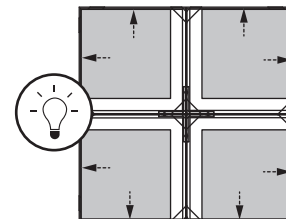
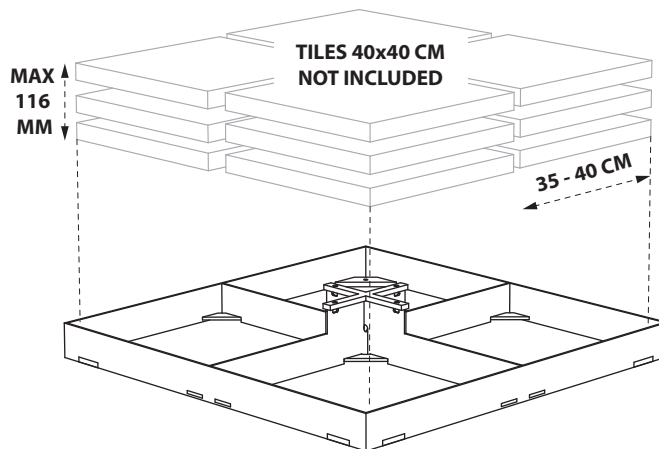

UMBROSA / 7

TILE BASE INSTALLATION

OPTIONAL : UMFIXTOPMOBA0000

3

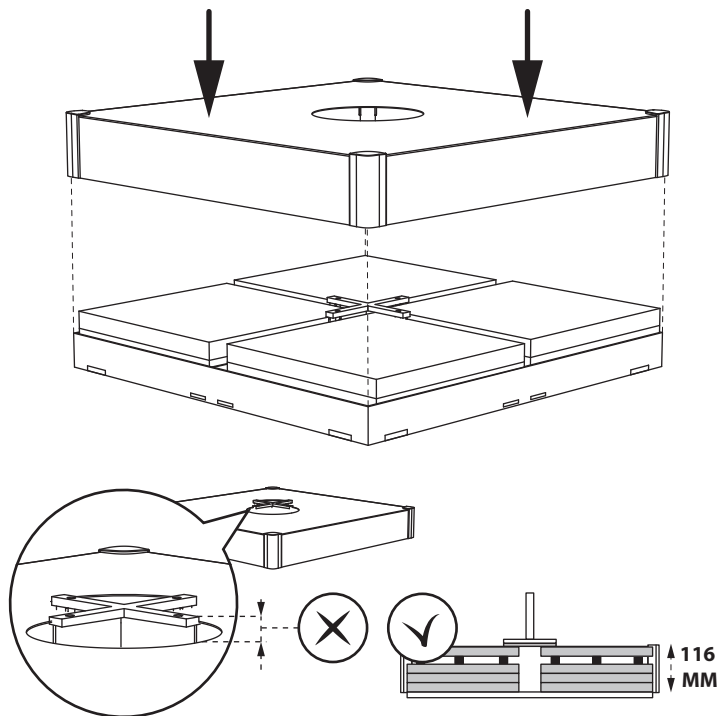

4

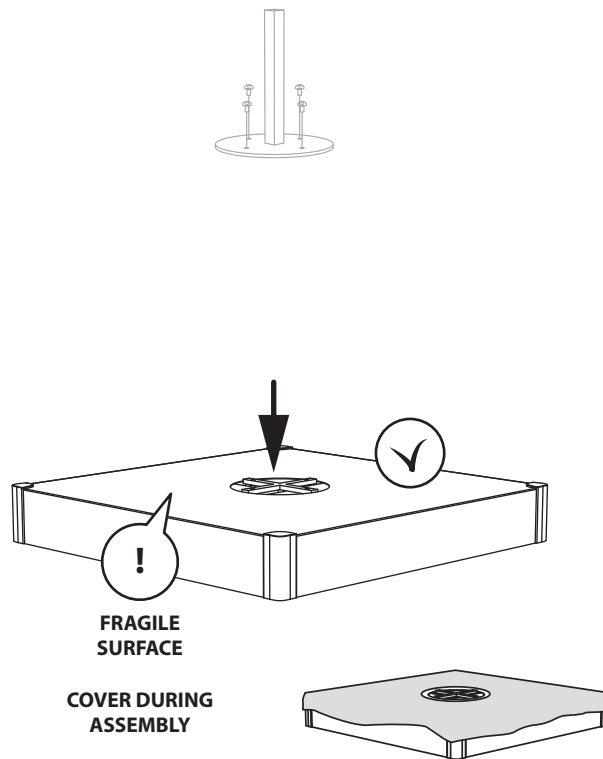

UMBROSA / 8



MOBILE CONCRETE BASE INSTALLATION

UMBASM80SET00000

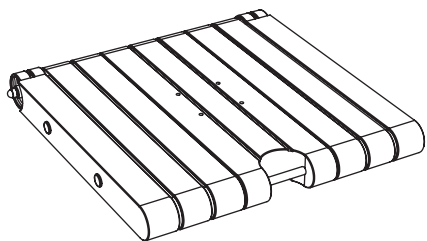

UMBASMHAN

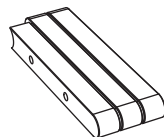

MABASM800R

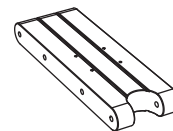

MABASM800M

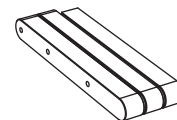

MABASM800L



MABOLI0650
4x



MACOMU002B
4x



HUTUBI0040
2x



HUAXIB0021
1x



MACOMU004C
4x



MACOMU002N
2x



MAWASI0110
2x



MANUTI0160
3x



HUBOLZ0010
+ **MANUTI0170**
2x



HUBOLZ0011
+ **MANUTI0170**
1x



MABOLI0530
6x



MACOMU018B
6x



MACOMU017B
2x



MACOMU005B
4x



19



55

MOBILE CONCRETE BASE INSTALLATION



1

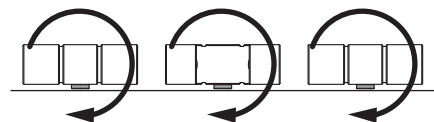
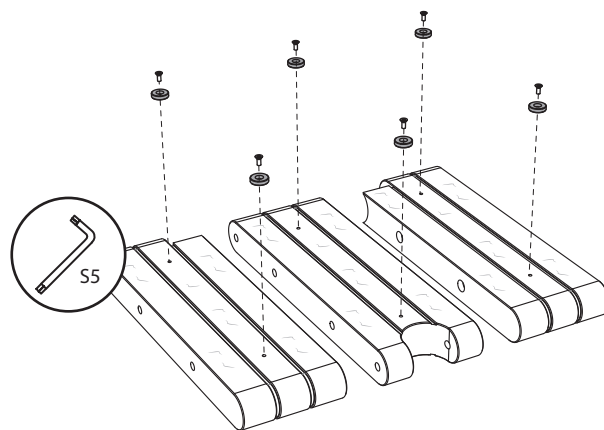
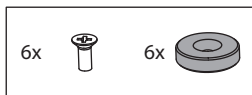

UMBROSA.COM

2

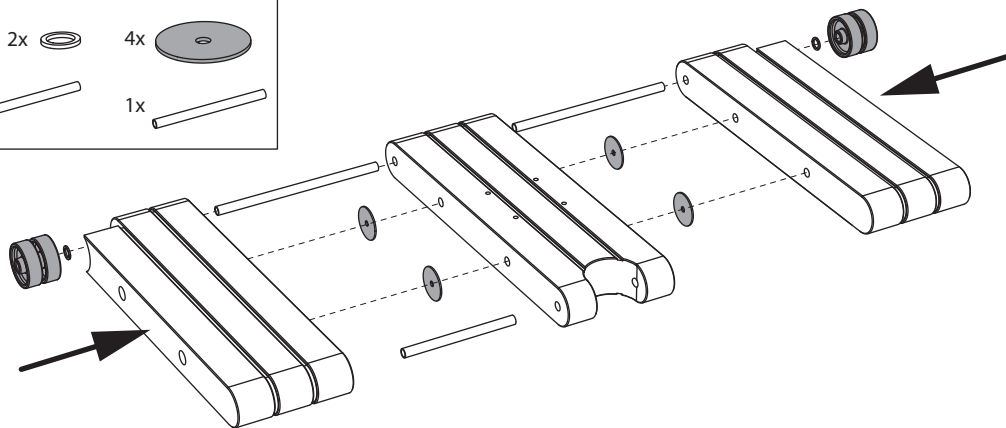
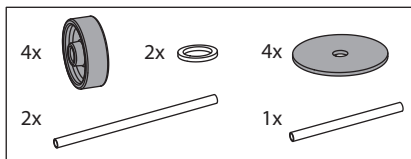

MOBILE CONCRETE BASE INSTALLATION



3

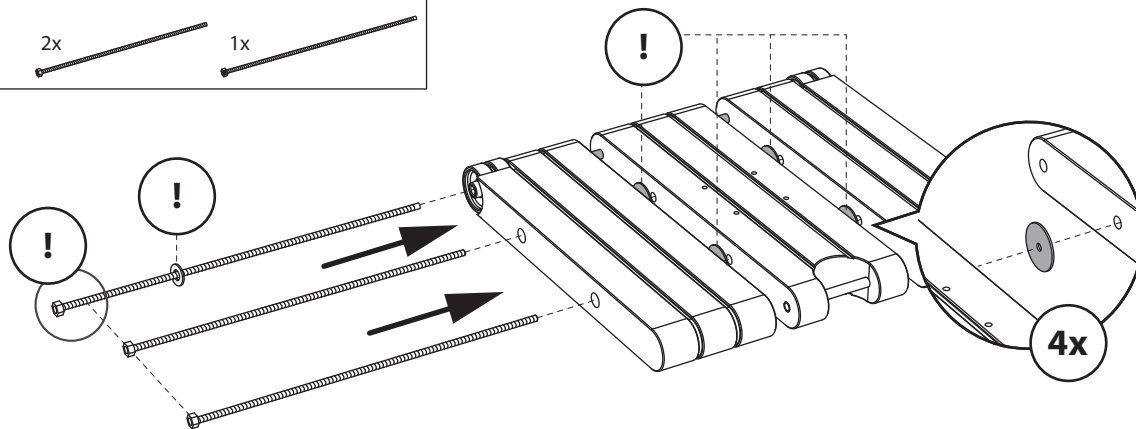
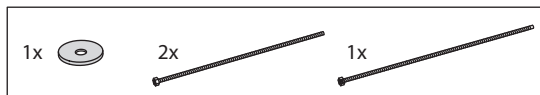

4

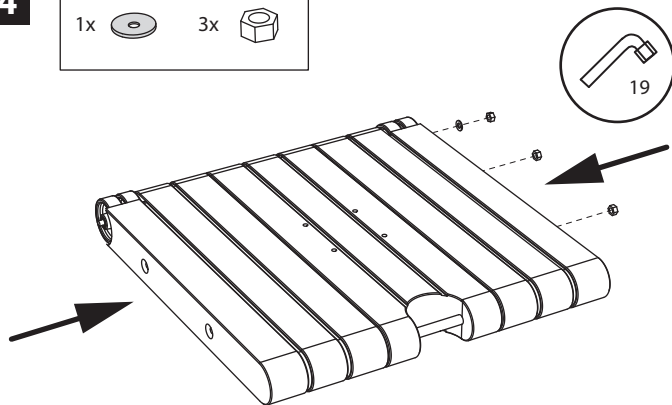
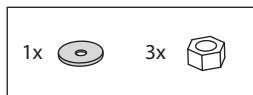

5

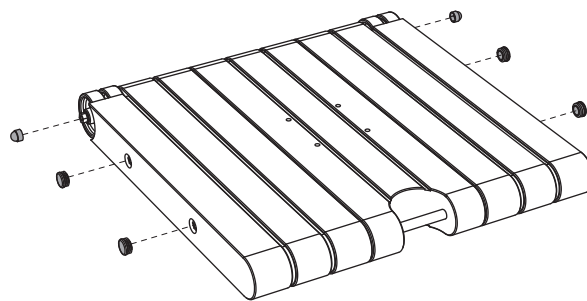
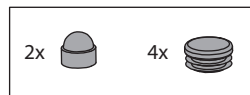

MOBILE CONCRETE BASE INSTALLATION

6

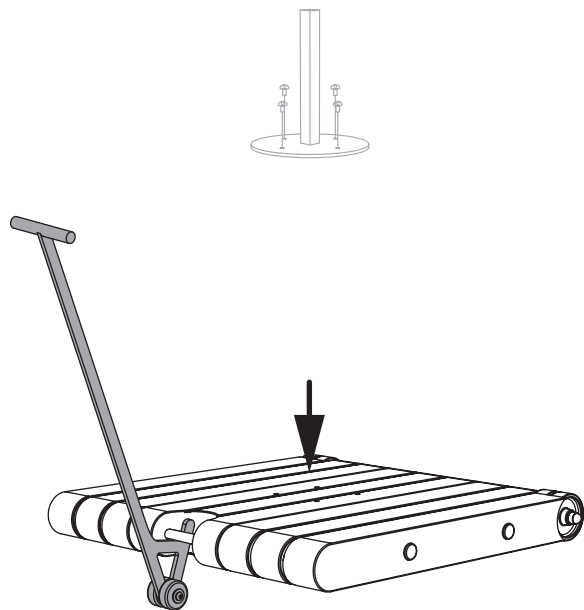

OPTIONAL : UMBASM80FL00EXT



7

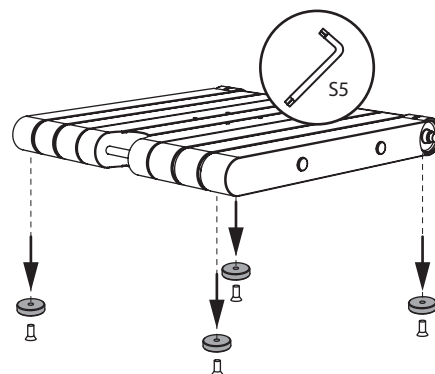

8

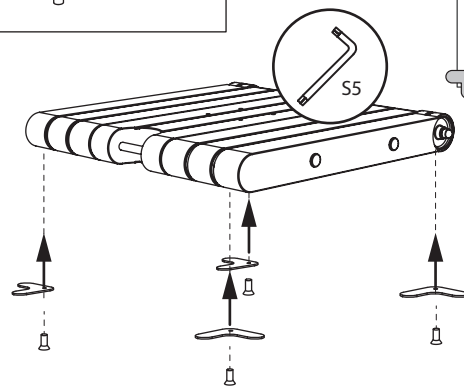
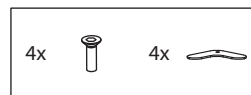

CONCRETE ANCHOR INSTALLATION

UMFIXCROTG000000

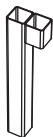
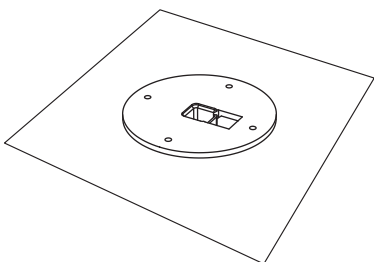

HITUBG0000

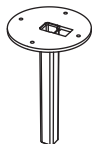

MAFIXCROTG000000

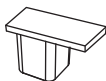

MAPLAI0060

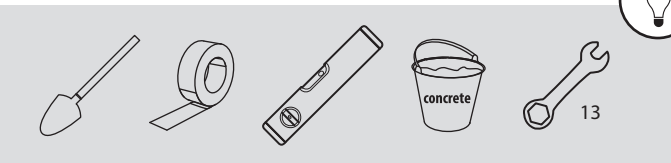

1

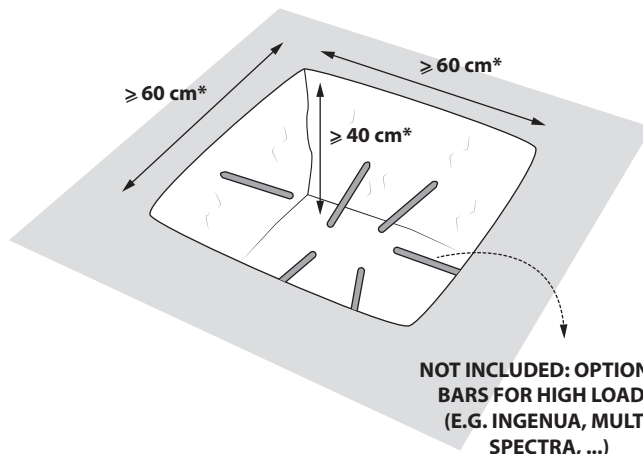

ENG Dimensions are indicative. Final responsibility always lies with the installer.

NL Maten zijn informatief. Eindverantwoordelijkheid ligt bij installateur.

FR Les dimensions indiquées sont seulement à titre informatif. La responsabilité finale incombe à l'installateur.

DE Die Maße sind nur informativ. Der Installateur trägt die Verantwortung für die Ausführung.

ES Los tamaños son solamente informativos. El instalador es responsable del acabado final.

IT Dimensioni sono indicative. La responsabilità finale spetta sempre all'installatore.

CONCRETE ANCHOR INSTALLATION



2

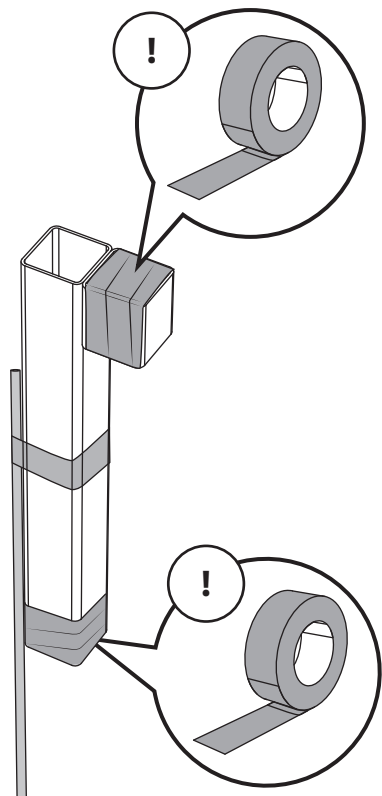

3

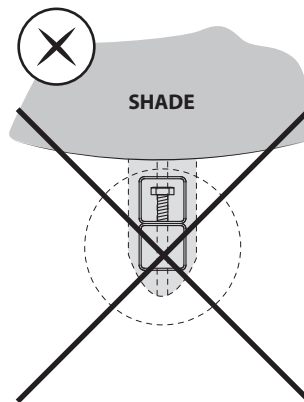
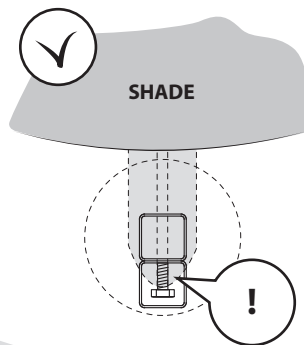
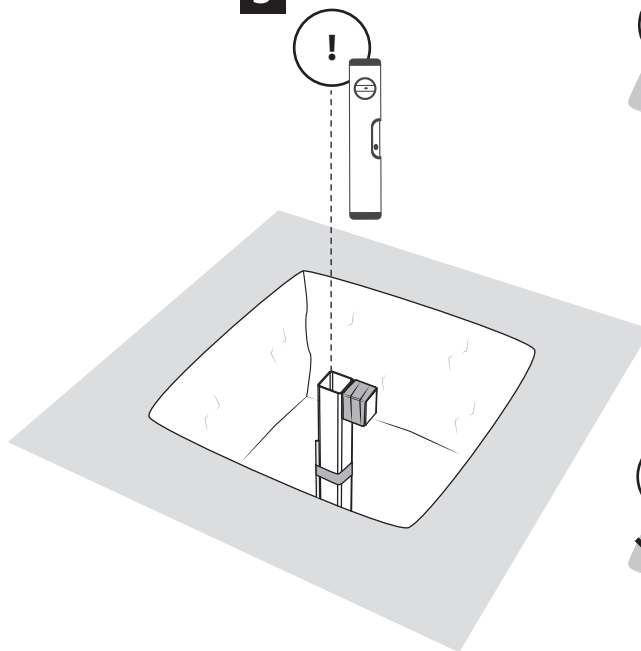

CONCRETE ANCHOR INSTALLATION



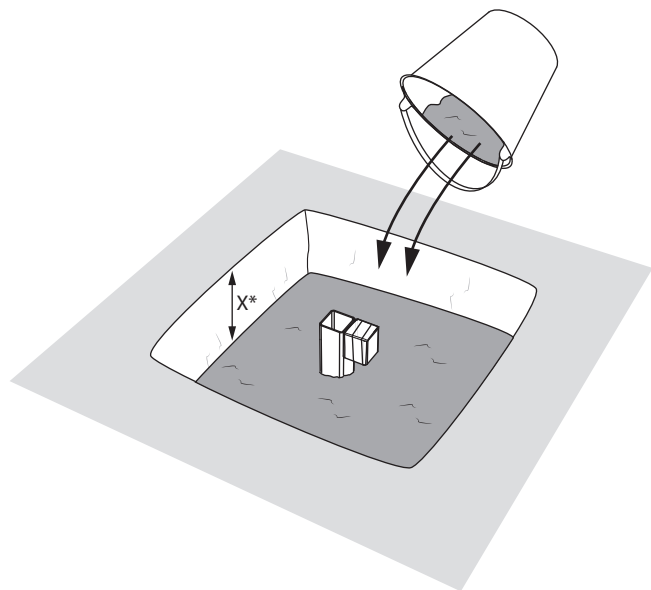

4

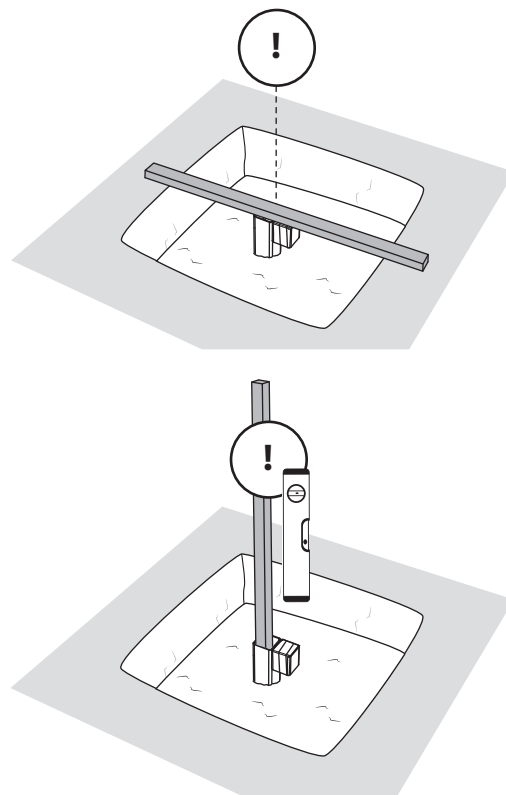

5



	 GRASS	 GRAVEL	 H ↑ TILES
↑ X* ↓	10 cm	4 cm	= H

CONCRETE ANCHOR INSTALLATION



6

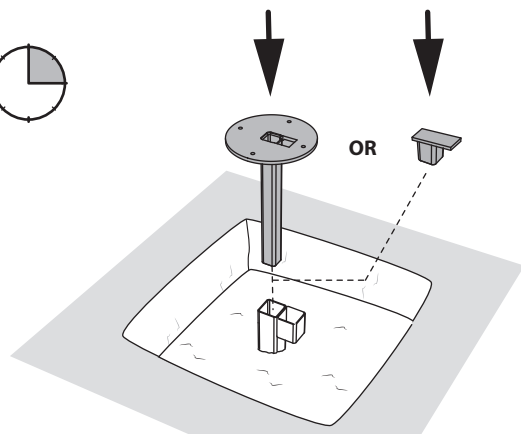

8

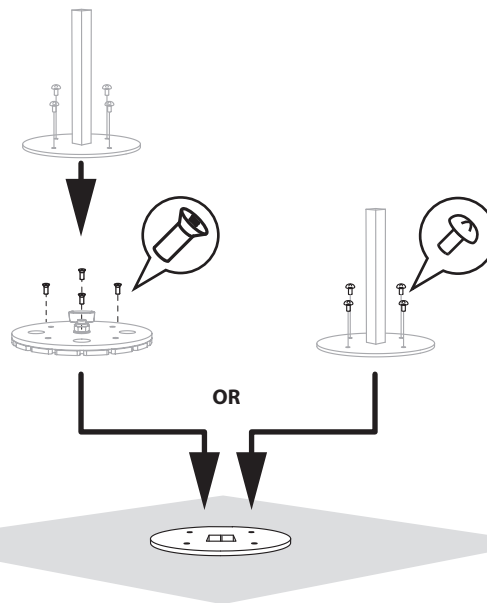

7

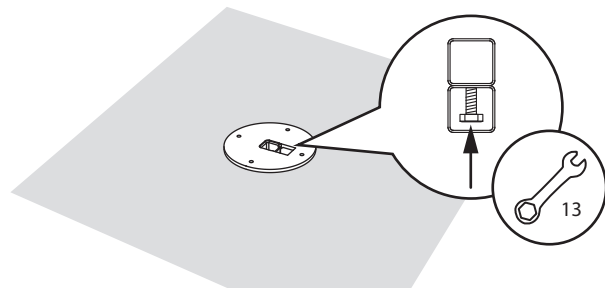

PARAFLEX WALL MOUNT

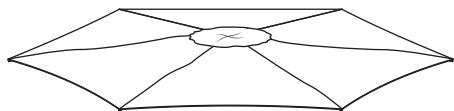
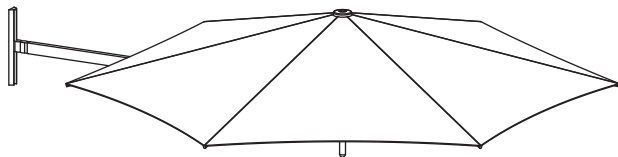

PFCOV

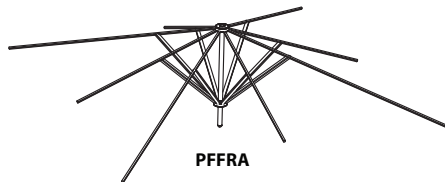

PFFRA

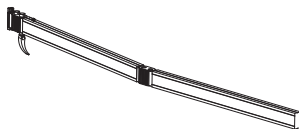

PFHOLS185S OR PFHOLS200SEVO

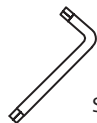

S5

MAKEY00060

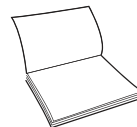

PFFIXW340A000000

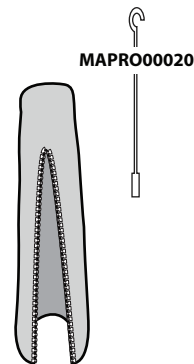

MAPRO00020

PFFPRO0192CGREY
(OPTIONAL)

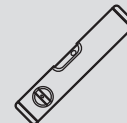

PARAFLEX WALL MOUNT

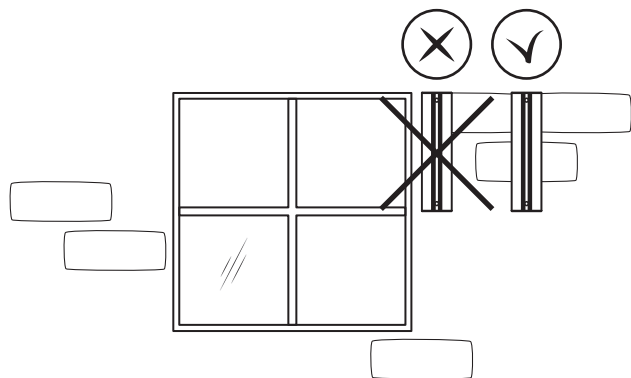

Not included - Niet inbegrepen - Pas inclus
Nicht inbegriffen - No incluido - Non incluso

DIN 7991 M8	Ø8 mm	Ø8 mm	DIN 7991 M8

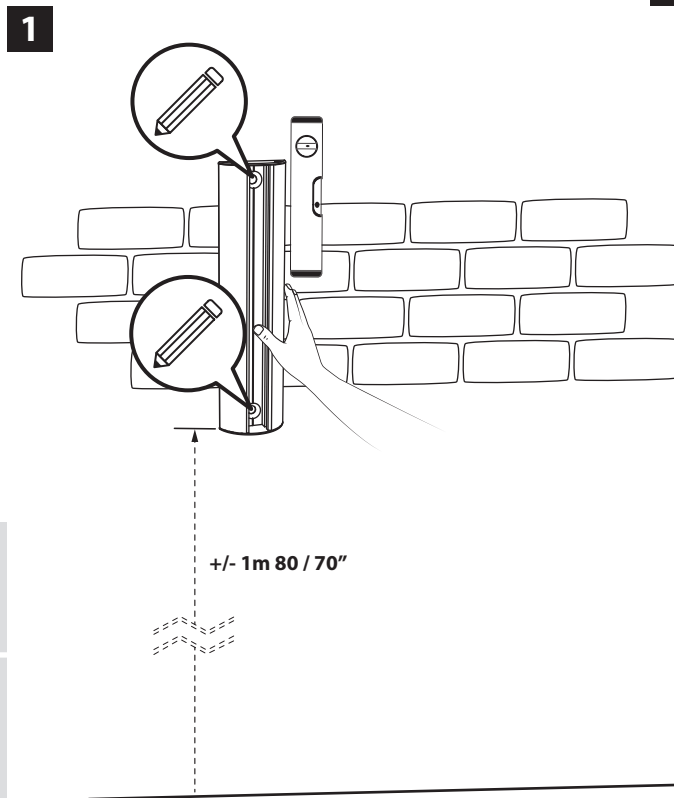

PARAFLEX WALL MOUNT



2

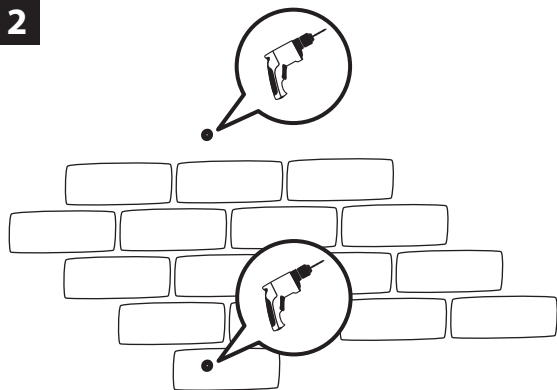

3

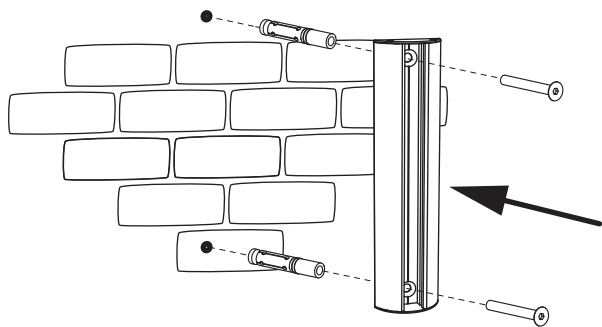

4

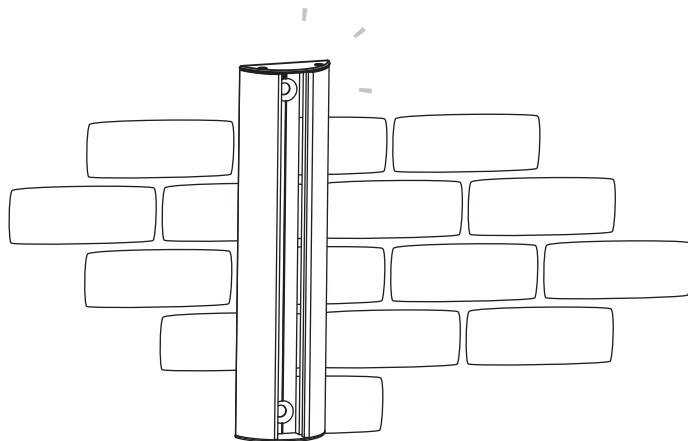

PARAFLEX HOLDER INSTALLATION



1

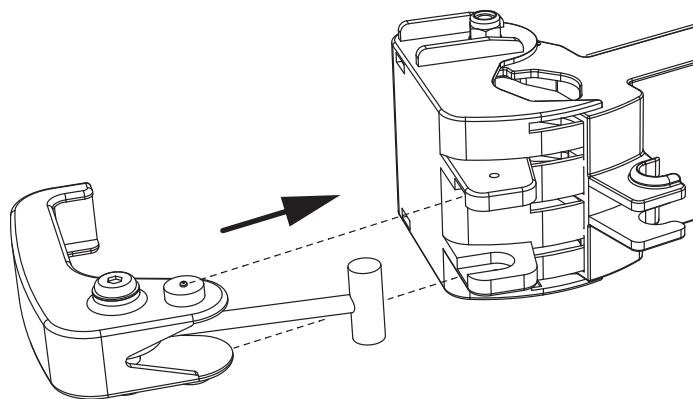

2

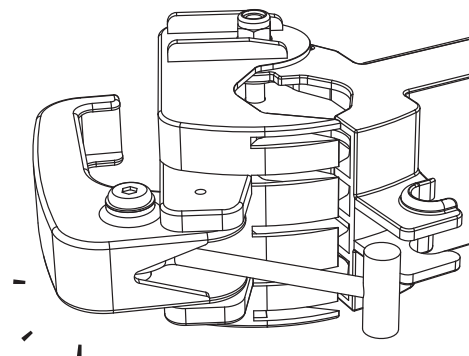

▶ p21 **PARAFLEX
EVOLUTION HOLDER
INSTALLATION**

▶ p22 **PARAFLEX
CLASSIC HOLDER
INSTALLATION**

PARAFLEX EVOLUTION HOLDER INSTALLATION



3

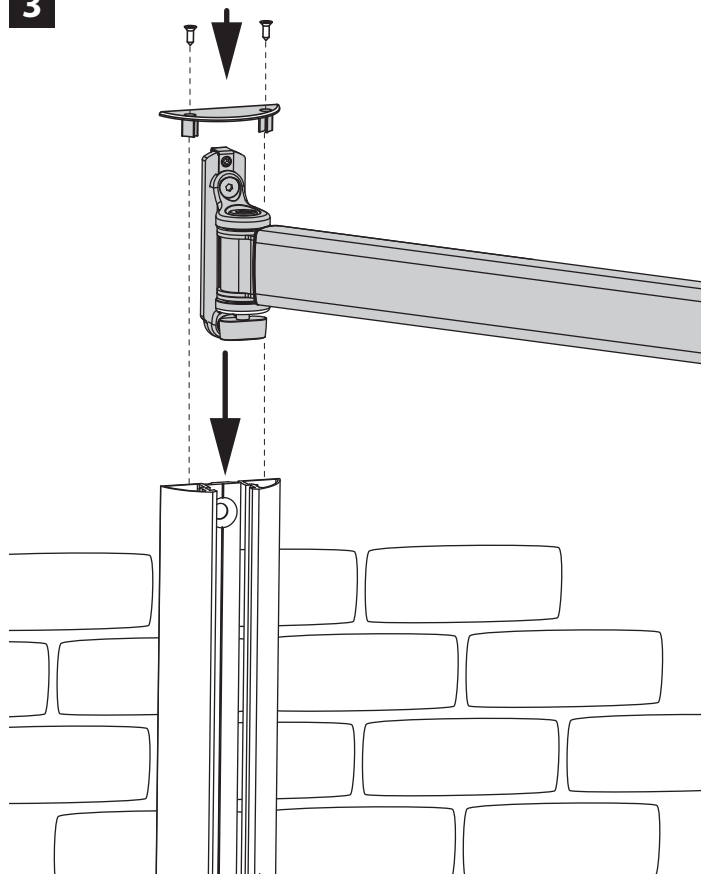

4

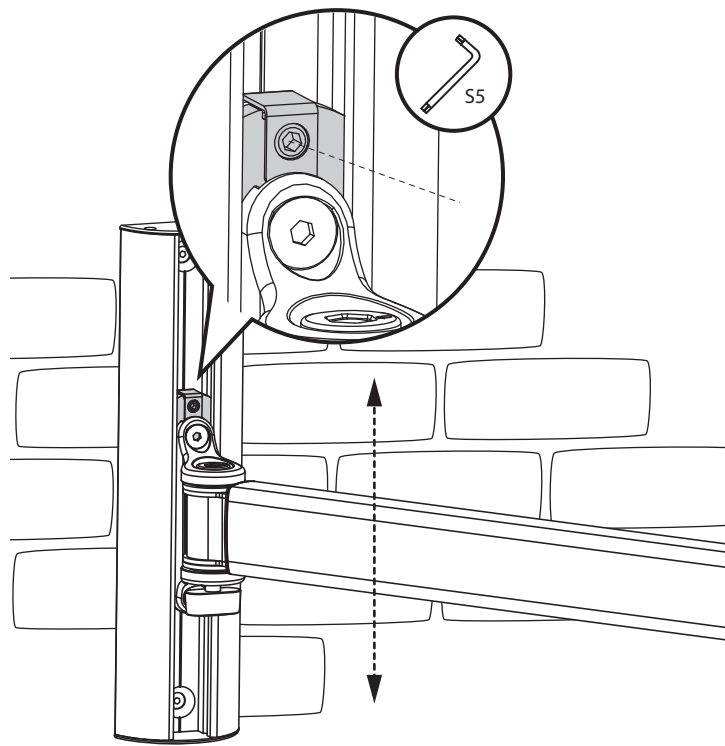

PARAFLEX CLASSIC HOLDER INSTALLATION



3

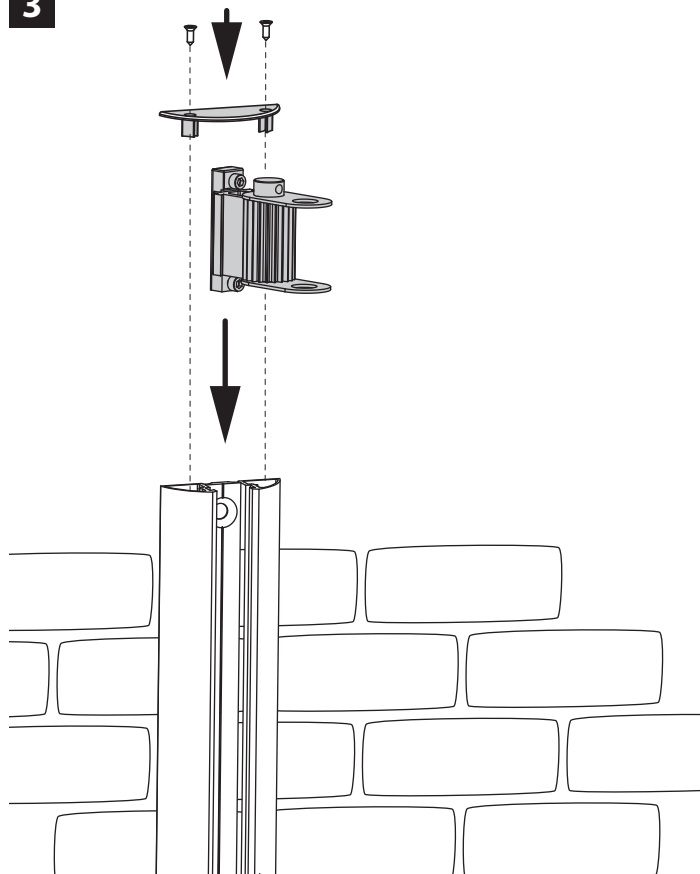

4

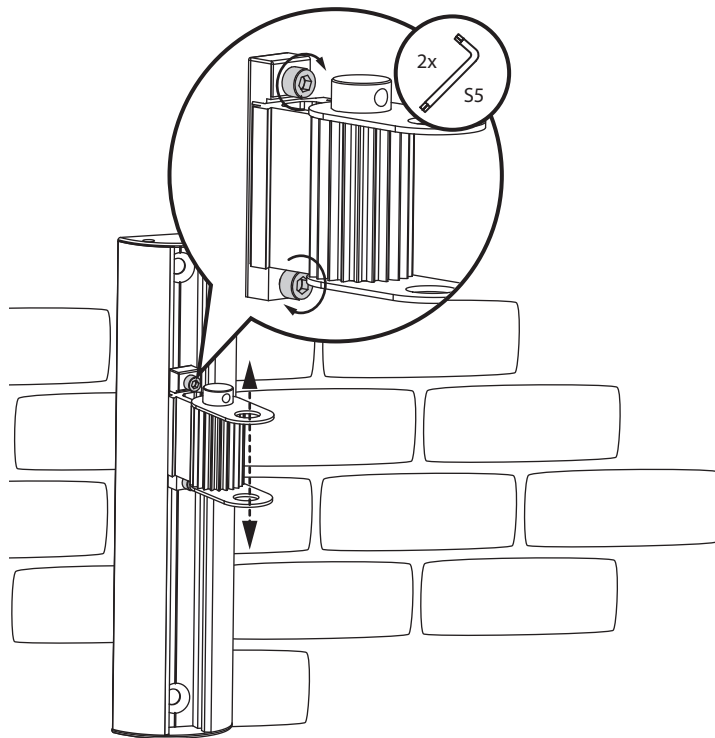

PARAFLEX CLASSIC HOLDER INSTALLATION



5

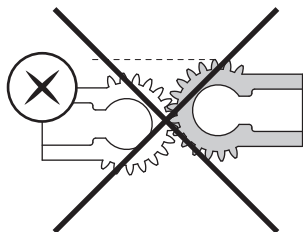
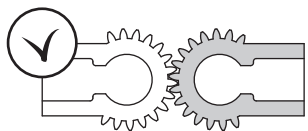

6

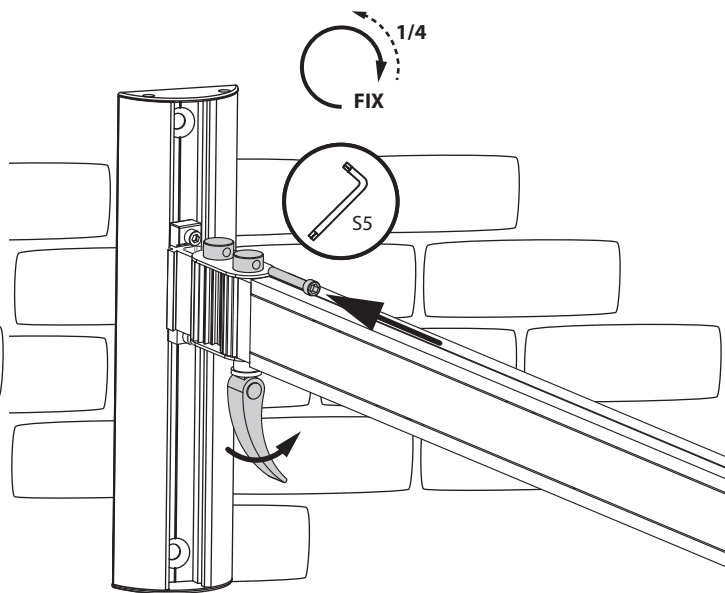
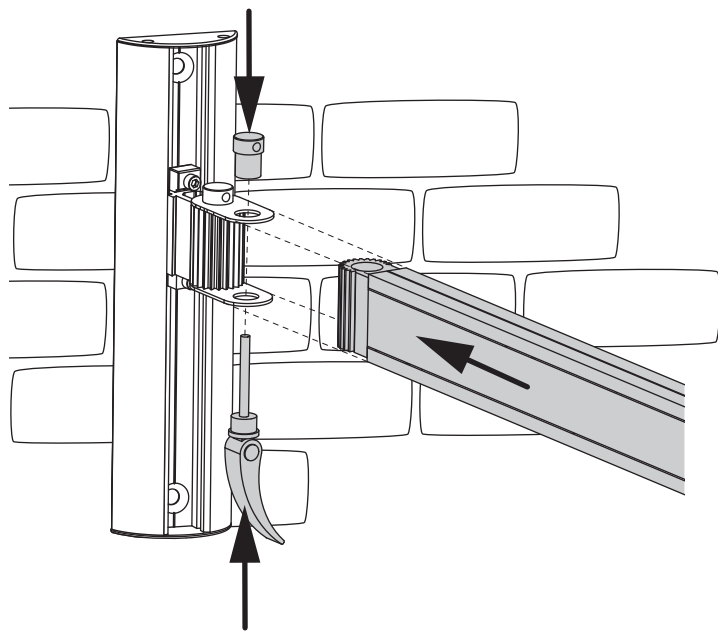

PARAFLEX SINGLE POLE INSTALLATION

PFPOSS220A000000

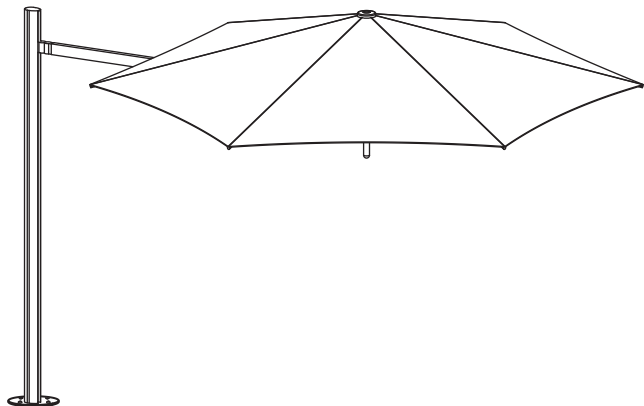

1

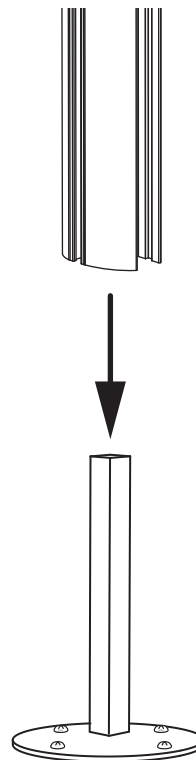

PARAFLEX SINGLE POLE INSTALLATION



2

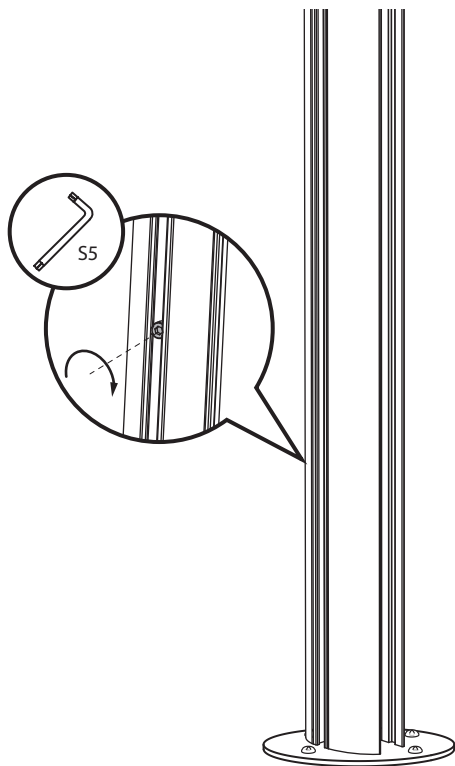

3

PARAFLEX EVOLUTION

▶ p21
**PARAFLEX
EVOLUTION HOLDER
INSTALLATION**

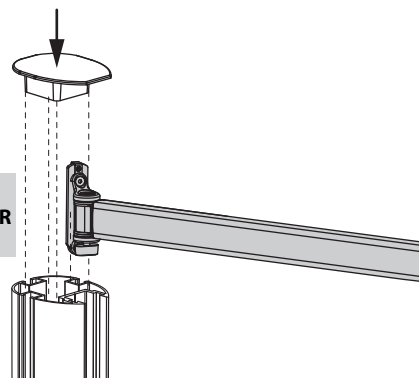

PARAFLEX CLASSIC

▶ p22
**PARAFLEX
CLASSIC HOLDER
INSTALLATION**

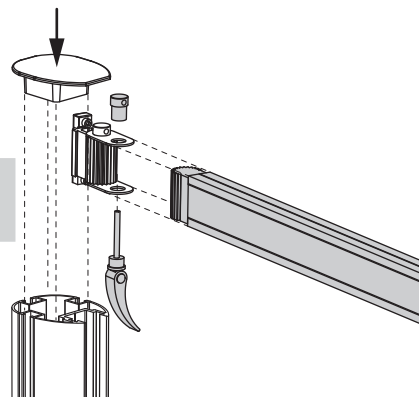

PARAFLEX MULTI POLE INSTALLATION

PFPOMS230A201500

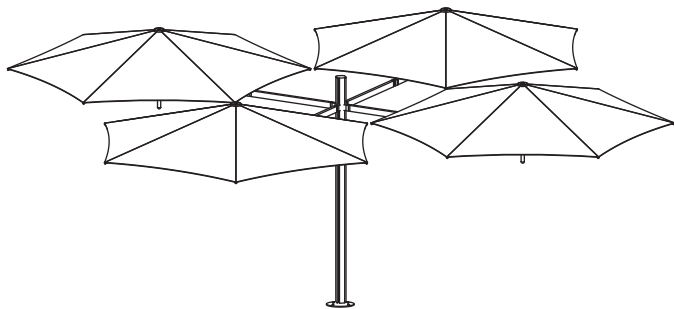

1



55

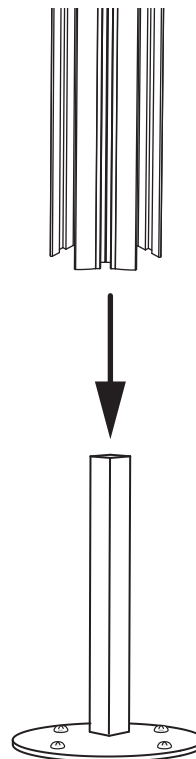
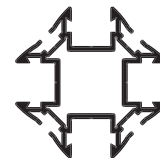



2

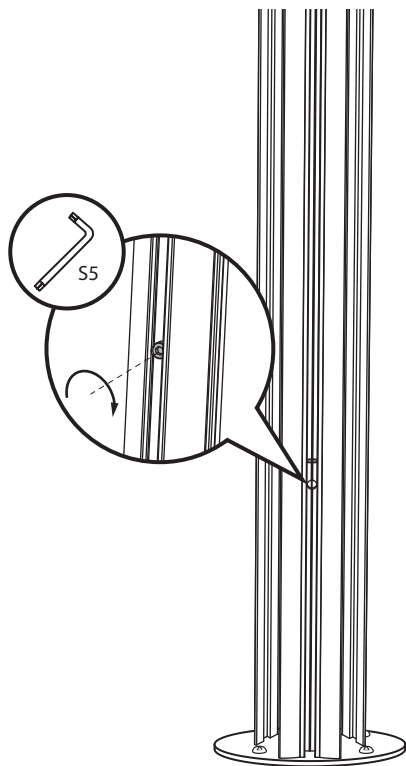

3

PARAFLEX EVOLUTION

▶ p21 **PARAFLEX EVOLUTION HOLDER INSTALLATION**

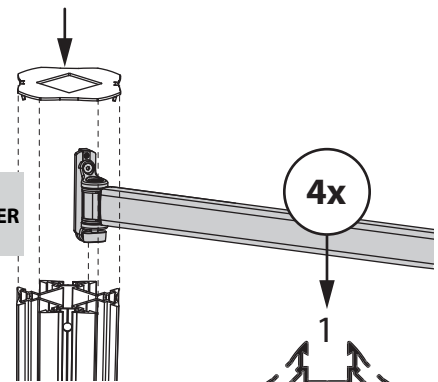

PARAFLEX CLASSIC

▶ p22 **PARAFLEX CLASSIC HOLDER INSTALLATION**

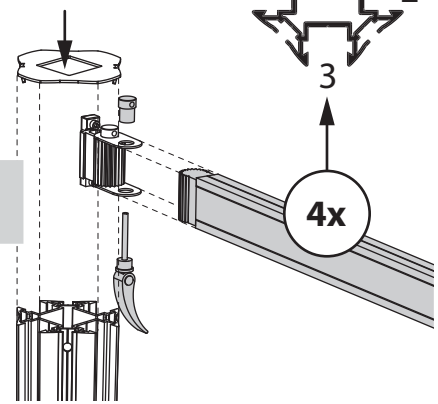

PARAFLEX MULTI 4+1 INSTALATION

PFPOTS025I000000



1

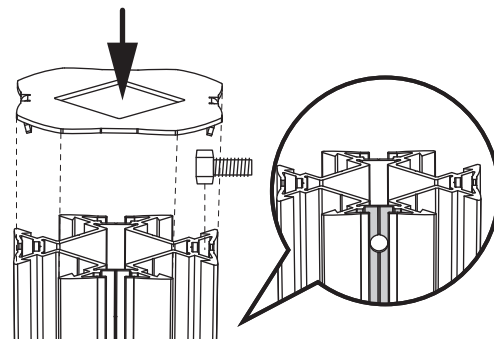
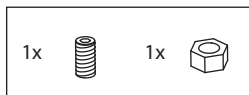

2

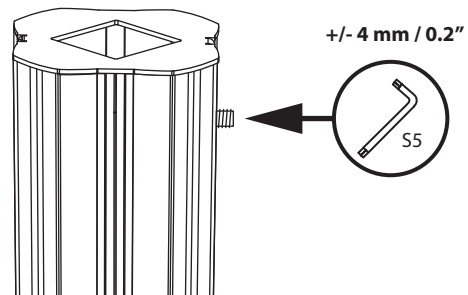

PARAFLEX MULTI 4+1 INSTALLATION



3

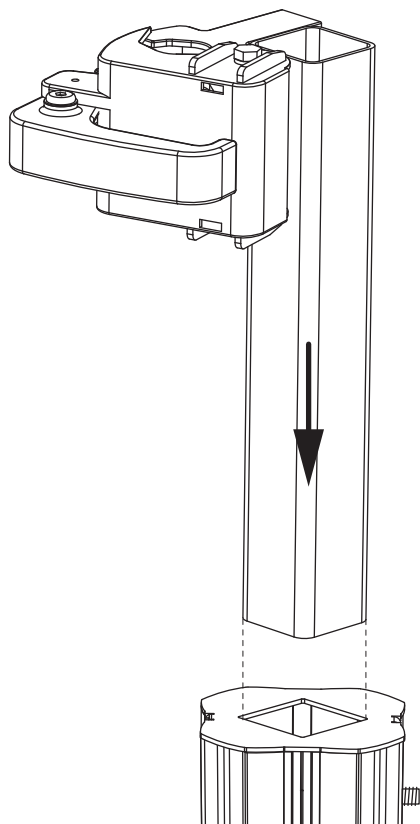

4

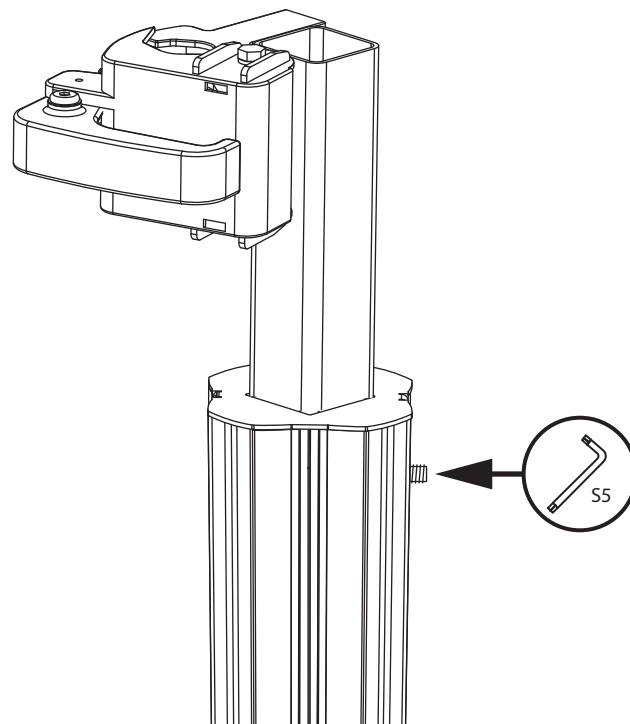

WALL BRACKET INSTALATION

PFFIXWBRAIHD0000

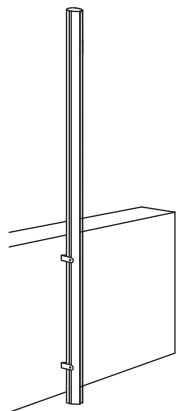

SINGLE

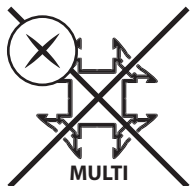

MULTI

Not included - Niet inbegrepen - Pas inclus
Nicht inbegriffen - No incluido - Non incluso

	DIN 9021 Ø8 mm	DIN 9021 Ø8 mm	DIN 9021 DIN 933 M8

1

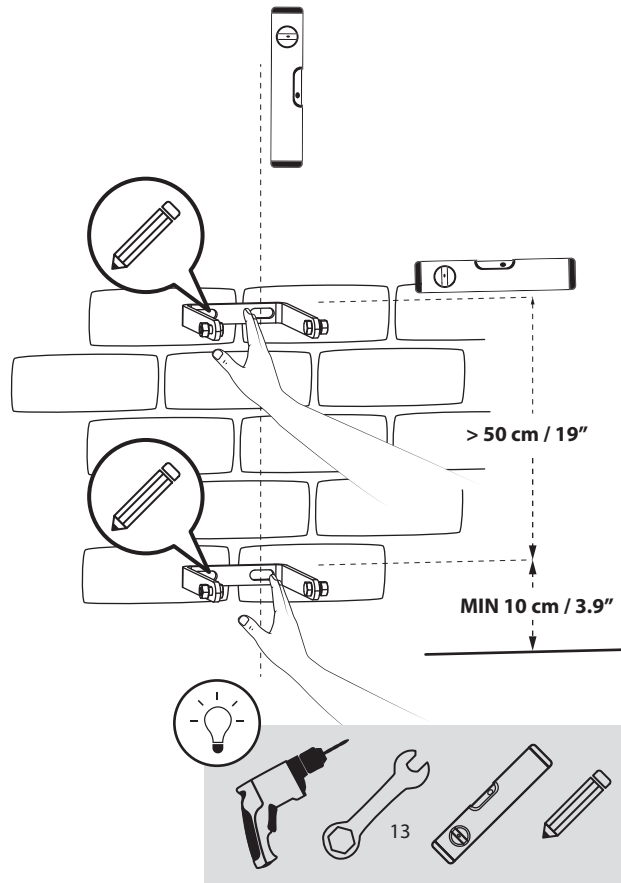

WALL BRACKET INSTALATION



2

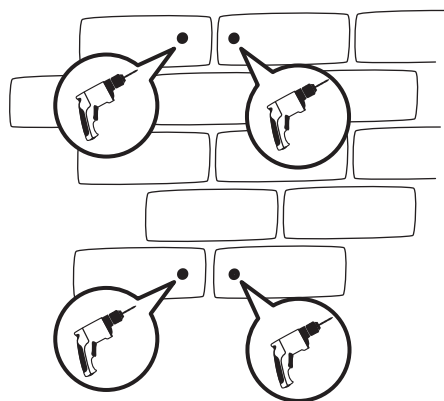

3

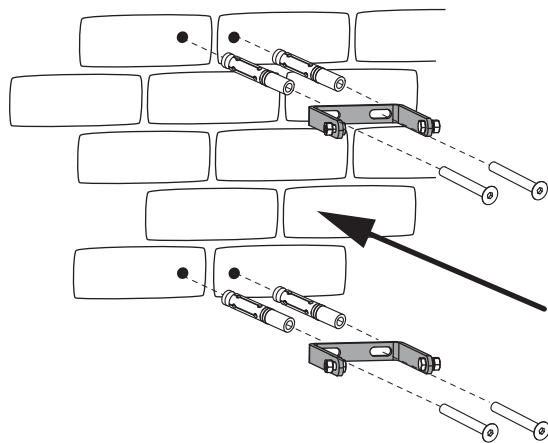

4

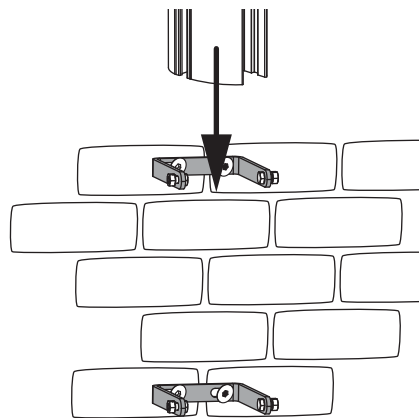

5

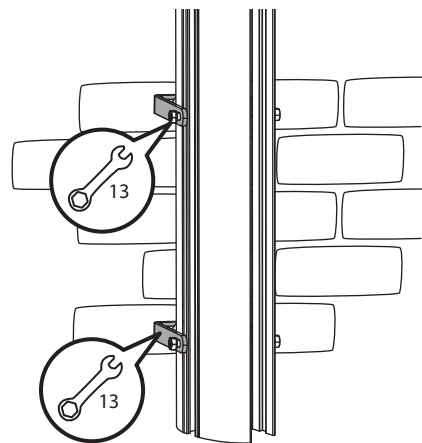

DUOFLEX HINGE

PFPOSDU00000000



ONLY FOR PARAFLEX CLASSIC ARM

1

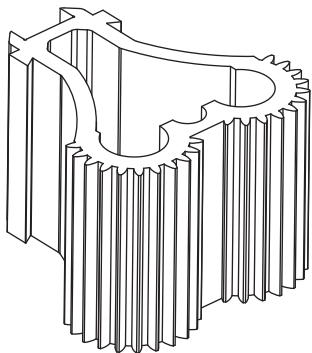

ONLY FOR PARAFLEX CLASSIC ARM

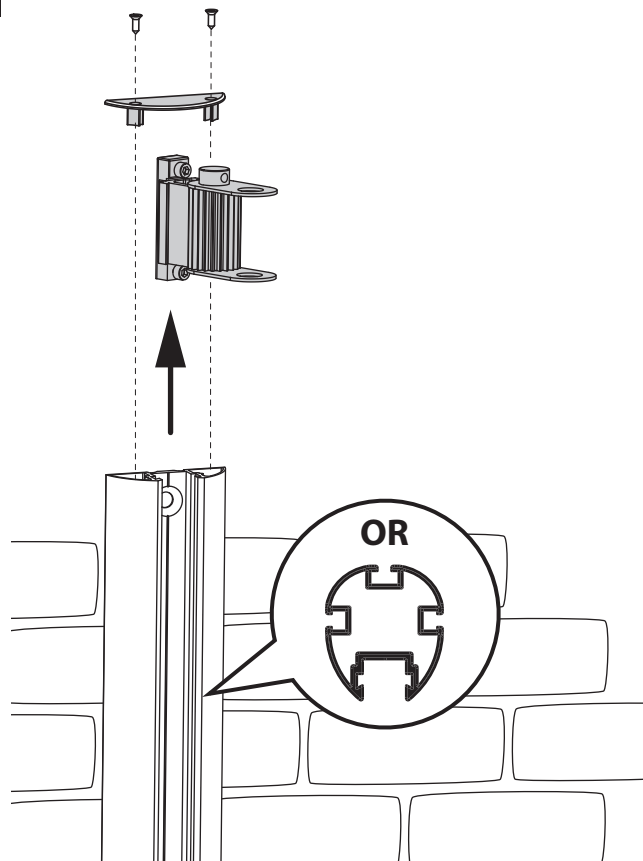

DUOFLEX HINGE

2

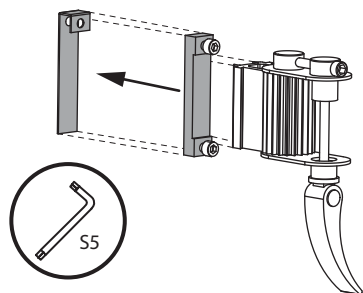

3

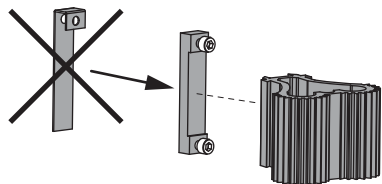

4

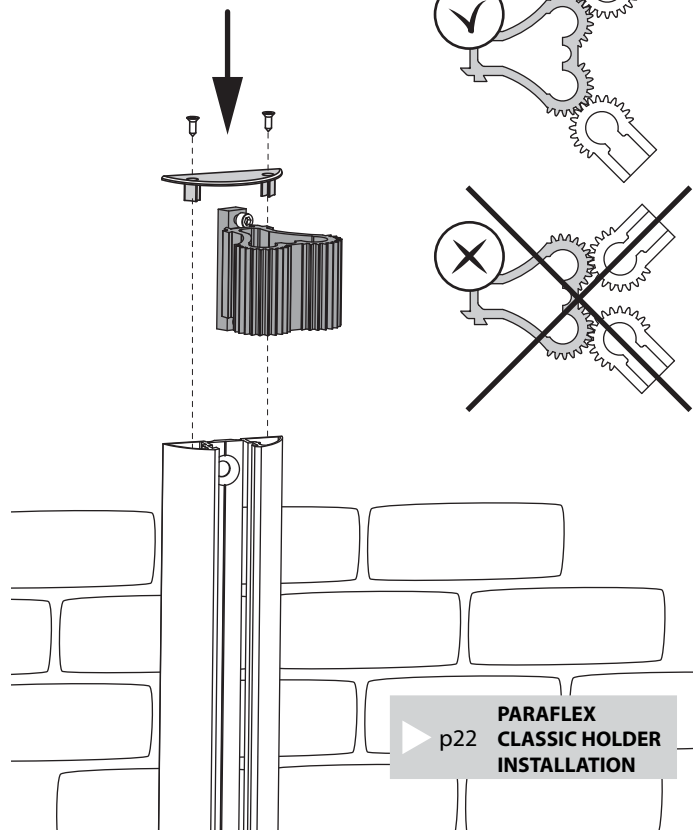

▶ p22 **PARAFLEX
CLASSIC HOLDER
INSTALLATION**

PARAFLEX CANOPY INSTALLATION

1

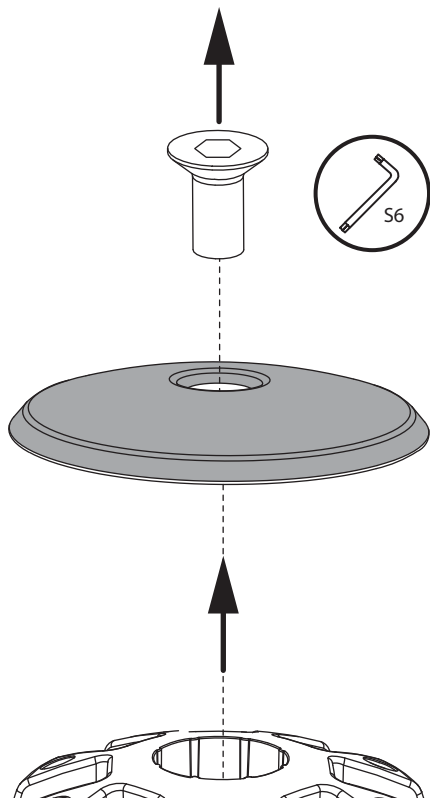

2

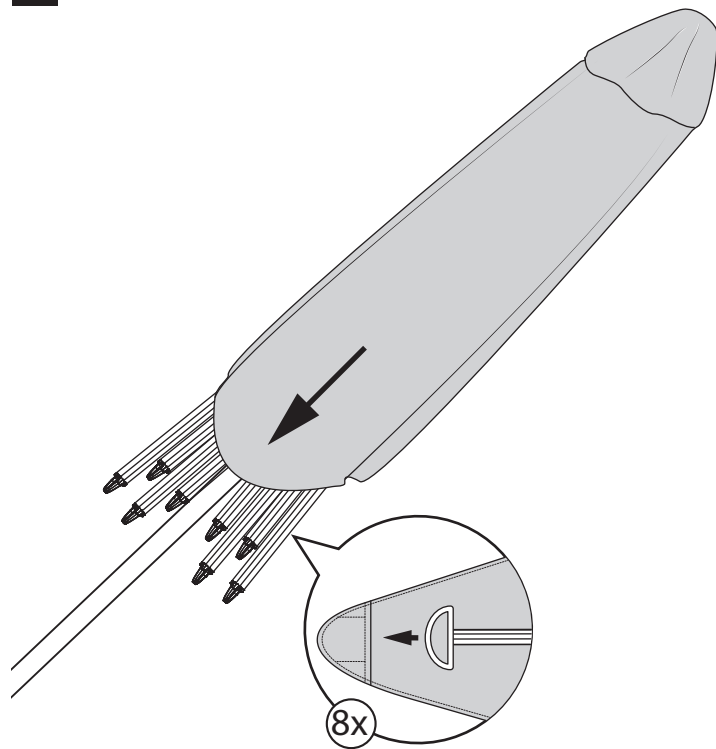

PARAFLEX CANOPY INSTALLATION



3

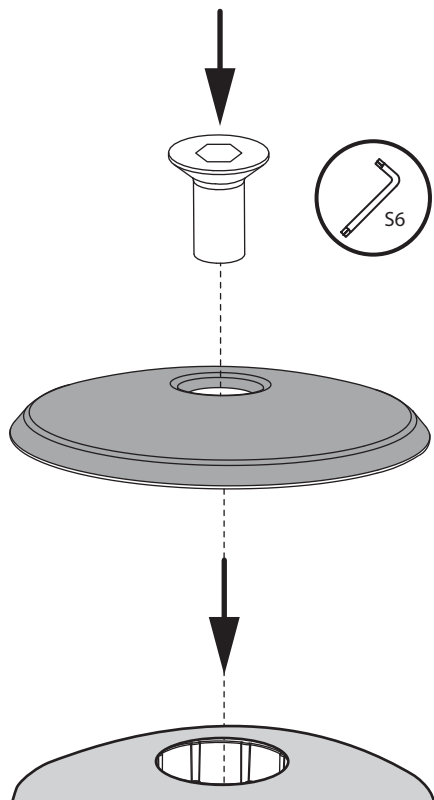

PARAFLEX USER INSTRUCTIONS



POSITION 1

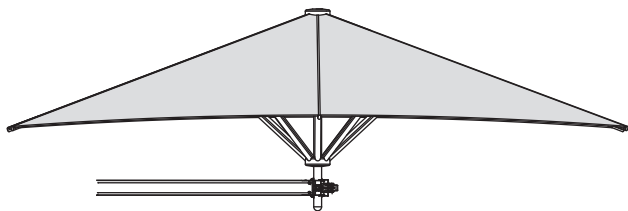

POSITION 2

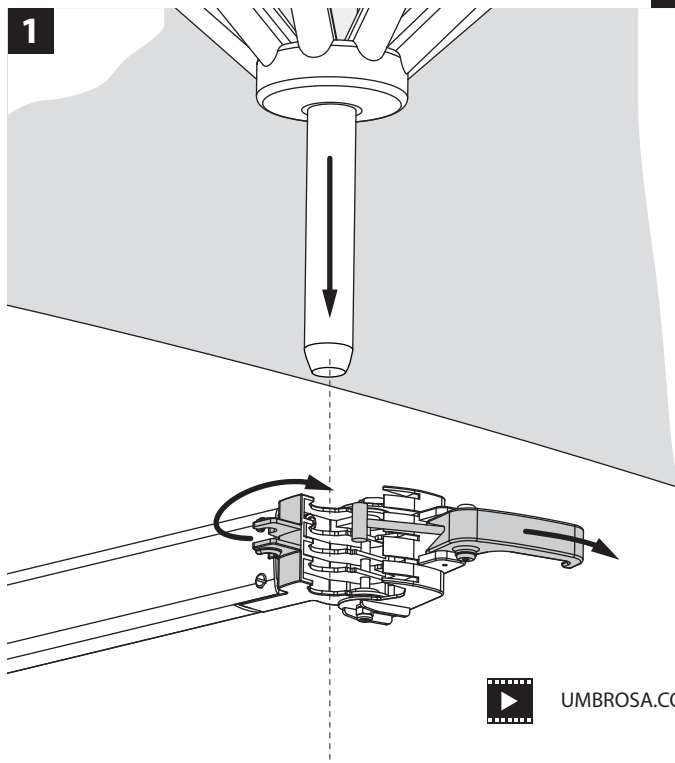
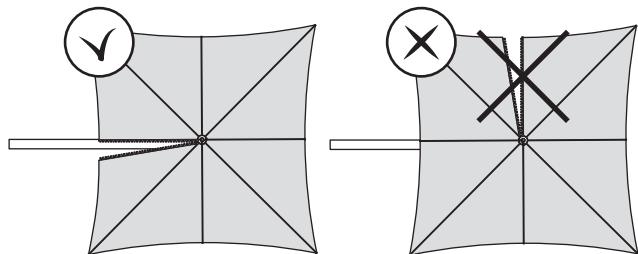
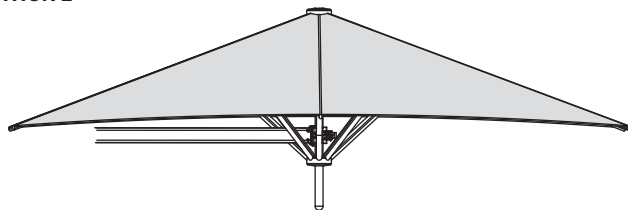

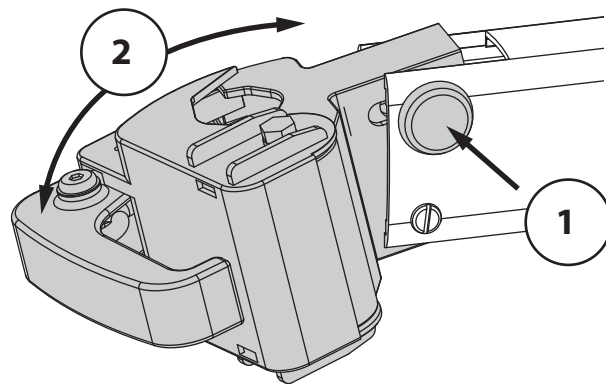
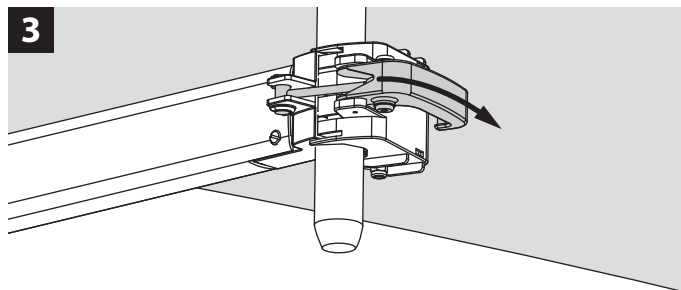
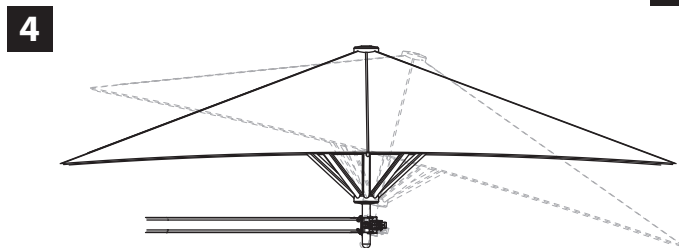
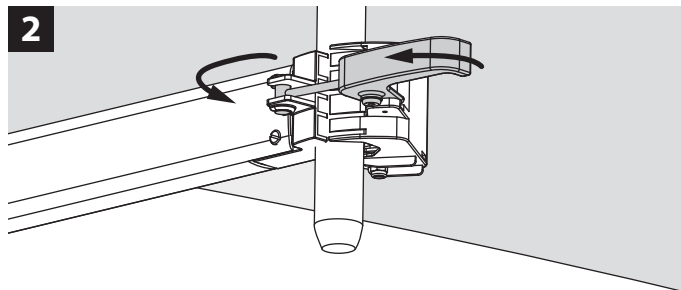



5

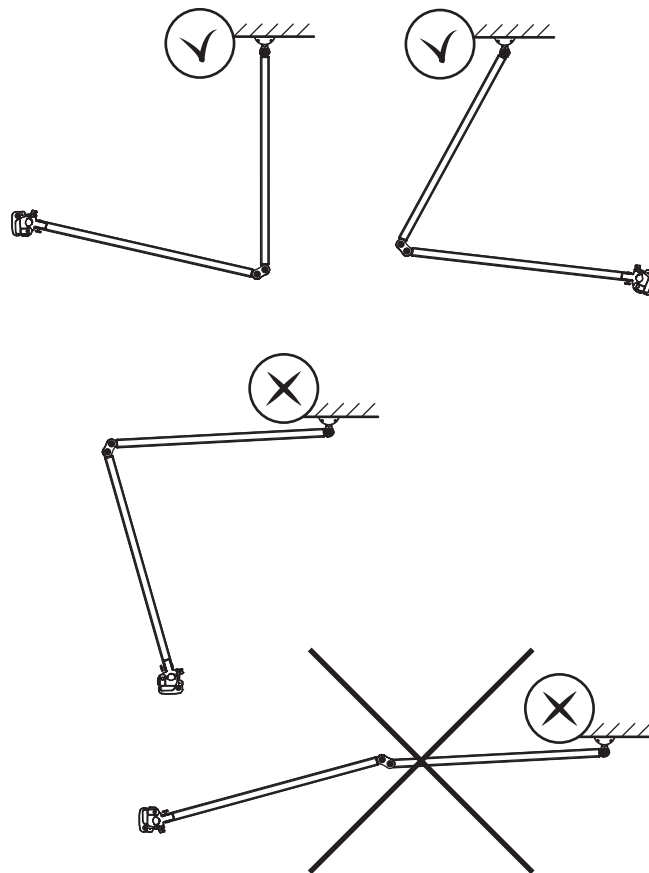
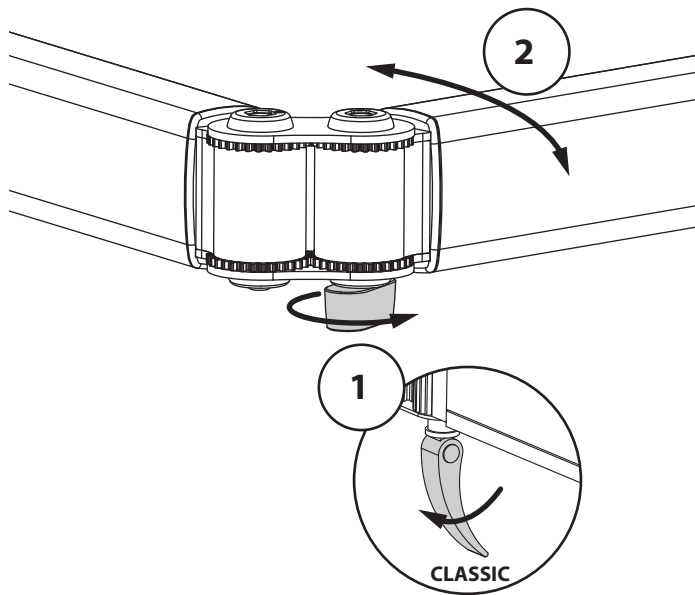



6

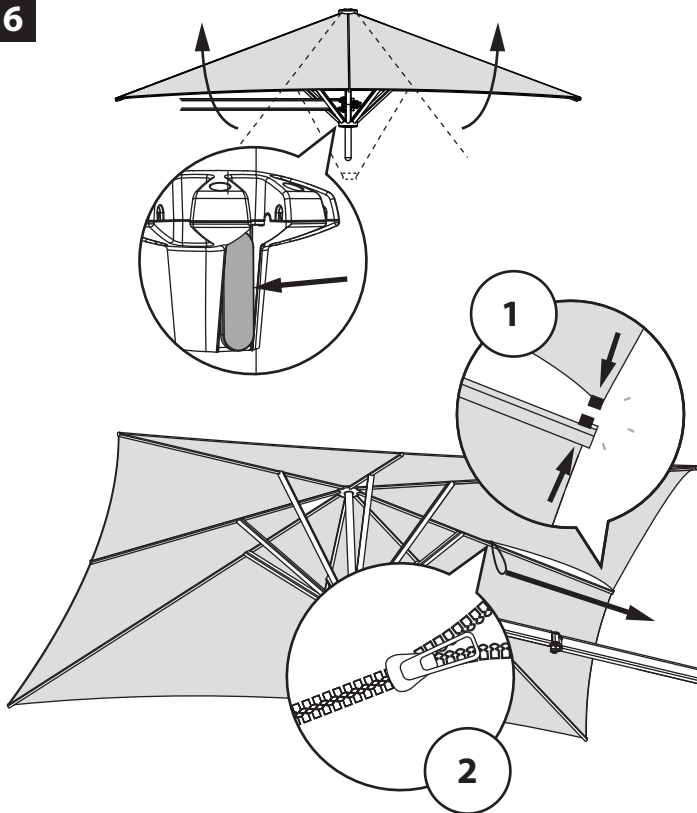

ENG We strive for a perfect cover tension with our Paraflex. The first time, you'll have to use more power to close the cover. From the second use, the cover will be formed and it will close more easily.

NL Met onze Paraflex streven wij naar de perfecte doekspanning. De eerste maal moet u veel kracht uitoefenen om het doek te sluiten. Vanaf het tweede gebruik zal het doek zich zetten, en zal sluiten vlot verlopen.

FR Nous aspirons à une tension de toile impeccable avec notre Paraflex. La première fois, vous voudrez exercer plus de force afin de fermer la toile. A partir de la deuxième utilisation, la toile s'adaptera et fermera plus facilement.

DE Mit unserem Paraflex streben wir nach einem perfekten Tuchspannung. Das erste Mal müssen Sie viel Kraft benutzen um den Tuch zu schließen. Ab dem zweiten Gebrauch wird das Tuch dehnen und wird es flotter schließen.

ES Con el Paraflex, nos afanamos por una tensión de lonas perfecta. La primera vez tiene que usar mucha fuerza para cerrar la lona. Desde el segundo uso, la lona adaptará y cerrará muy fluidamente.

IT Anche per il ns. modello Paraflex, ci impegniamo per ottenere una perfetta tensione del telo. La prima volta, e' normale che ci vuole più forza per aprire il telo. A partire dal secondo utilizzo, il telo avrà già preso la sua forma e sarà più facile aprire l'ombrellone.



7

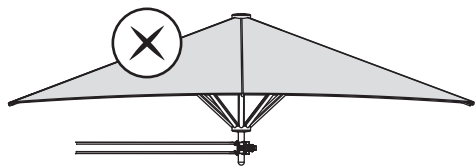
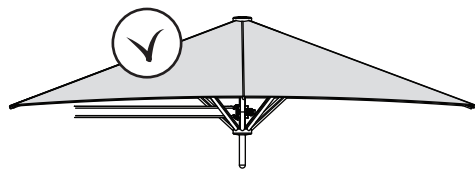
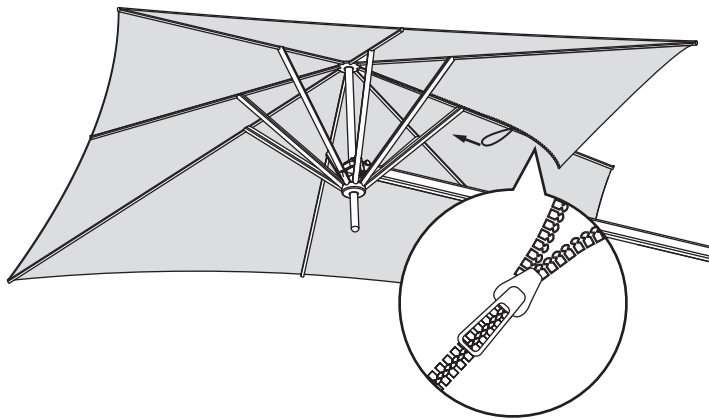

8

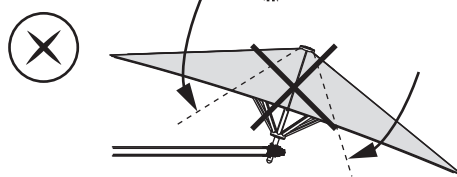
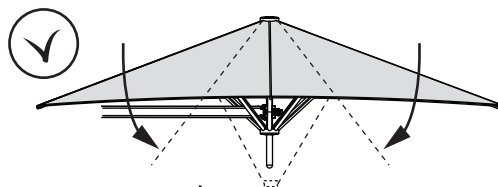
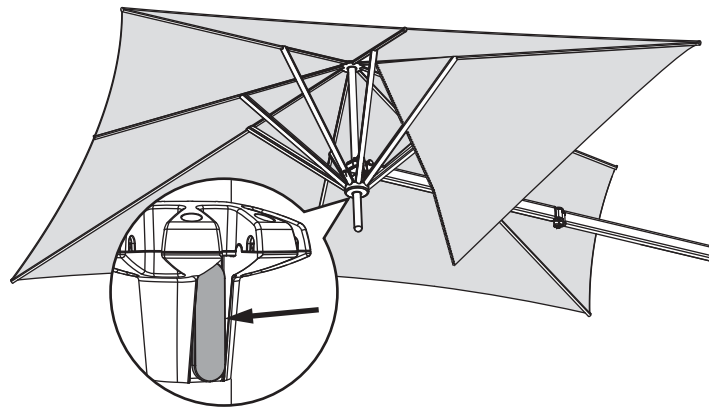

PARAFLEX USER INSTRUCTIONS

OPTIONAL : PFP00192CGREY

9

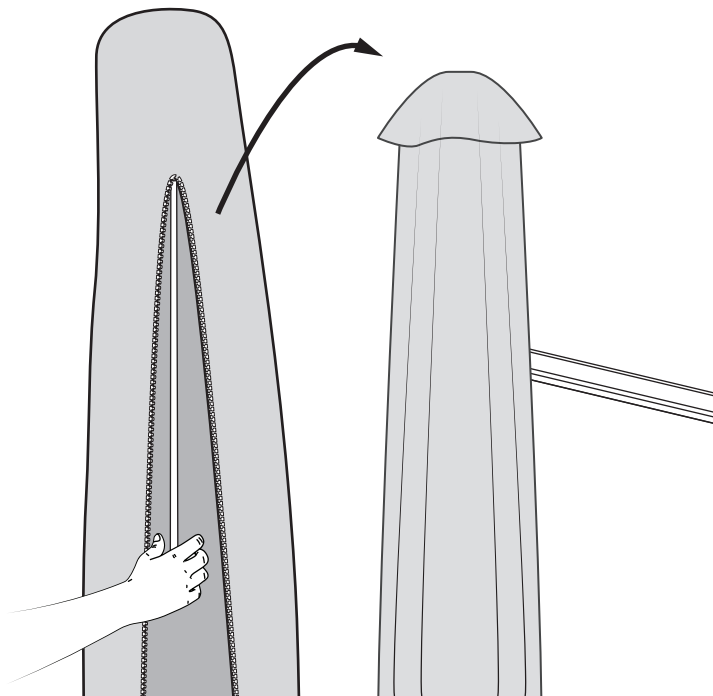

10

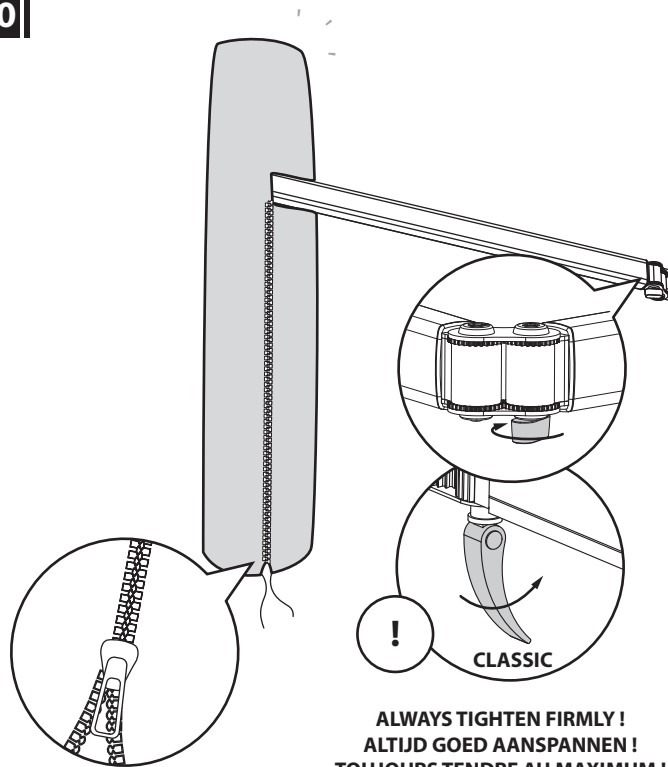

**ALWAYS TIGHTEN FIRMLY !
ALTIJD GOED AANSPANNEN !
TOUJOURS TENDRE AU MAXIMUM !
IMMER GUT ANSPANNEN !
SIEMPRE TENSIONAR BIEN !
STRINGERE BENE !**



TIPS



> 30 KM/H
> 5 BEAUFORT

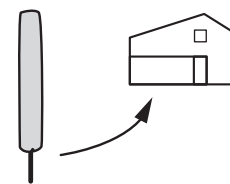
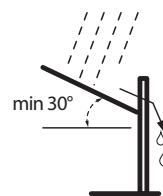
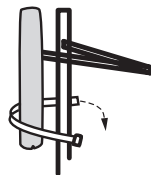

MAINTENANCE

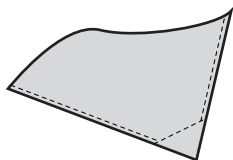

UMBROSA
WATER REPELLENT SPRAY



UMBROSA
MAINTENANCE KIT



- ENG** In order to **prevent stainless steel from rusting**, it is necessary to treat it frequently and preventatively. Umbrosa recommends cleaning and protecting the surface regularly. Cleaning can easily be done using standard dishwashing detergents. Afterwards, a protection layer can be applied onto the dry surface with a silicon spray. In an aggressive environment (maritime climate, chlorine, acid rain, aggressive industrial or urban environment) we recommend to clean the surface more frequently. Rust can be removed using a cloth and polishing paste. These kinds of products can be bought in do-it-yourself shops, but also in car specialty stores that sell several “stainless steel polishers”.
- NL** **Roestvast staal blijft enkel vrij van corrosie**, wanneer deze goed en preventief wordt behandeld. Umbrosa raadt bijgevolg aan om regelmatig het oppervlak te reinigen en beschermen. Reinigen kan eenvoudig met warm water met afwasmiddel zoals “Dreft”. Nadien brengt u op het droge oppervlakte een bescherm laag aan met bijvoorbeeld Silicone spray. In een agressieve omgeving (maritiem klimaat, chloor, zure regen, agressieve industriële of stedelijke omgeving), dient men de frequentie van dit preventief onderhoud op te drijven. Wanneer lichte roest zichtbaar is, dient deze te worden verwijderd met doek en speciale polierpasta. Dergelijke producten zijn te koop in Doe-het-Zelf zaken, alsook in autospecialzaken waar men verschillende “stainless steel polishers” verkoopt.
- FR** Pour **éviter que L’acier inoxydable corrode**, c’est nécessaire de traiter la surface régulièrement. Umbrosa conseille de nettoyer et protéger régulièrement la surface en utilisant l’eau chaude et un peu de détergent. Après, sur la surface sèche, vous pouvez appliquer une couche de protection avec, par exemple, un spray de Silicone. Surtout dans un environnement agressif (climat maritime, chlore, pluie acide, environnement industriel ou urbaine agressif) nous recommandons de nettoyer fréquemment la surface. Vous pouvez éliminer des éventuelles taches de rouille avec un chiffon et du cirage. Vous pouvez trouver ce type de produits dans des magasins bricolage, mais aussi dans des magasins spécialisés, ou on vend plusieurs “stainless steel polishers”.
- DE** **Edelstahl bleibt nur frei von Korrosion**, wenn dieser gut und Präventiv behandelt wird. Umbrosa empfiehlt regelmäßig die Oberfläche zu reinigen und zu schützen. Reinigung kann problemlos mit warmem Wasser mit Seife. Danach bearbeiten Sie die trockene Oberfläche mit einer Schutzschicht z.B. Silikon spray. In einem aggressiven Umfeld (Seeklima, Chlor, saurer Regen, aggressive Industrie- oder städtischen Umwelt) sollte man diese Behandlung häufig machen. Sichtbaren Rost sollte mit Tuch und spezielle Polierwerkzeuge Paste entfernt werden. Solche Produkte findet man in Baumärkten sowie in Auto Läden wo man verschiedene “Edelstahl Polierer verkauft”.
- ES** **Acero inoxidable sólo permanece libre de corrosión**, cuando esta bien y se trata como una medida preventiva. Umbrosa recomienda de limpiar regularmente la superficie para y proteger. Limpieza puede fácilmente con agua tibia con jabón del plato. Luego, lleva sobre la superficie seca con una capa protectora para por ejemplo spray de silicona. En ambientes agresivos (clima marítimo, cloro, lluvia ácida, agresivo ambiente urbano o industrial), la frecuencia de este mantenimiento preventivo para arriba. Cuando el moho visible, se debe retirar con paño y pasta de pulir especial. Estos productos se venden en ferreterías, así como en tiendas de coches donde uno diferentes vende “pulidores de acero inoxidable”.
- IT** Per **prevenire l’arruginirsi dell’acciaio inox**, è necessario curarlo frequentemente e preventivamente. Umbrosa consiglia di pulire e proteggere frequentemente la superficie. E’ possibile pulire l’acciaio inox con acqua calda e detergente. Dopo aver pulito la superficie, la potete proteggere applicando sulla superficie asciutta uno strato protettivo con, per esempio, lo spray al silicone. In un ambiente aggressivo (clima marittimo, cloro, pioggia acida, ambiente aggressivo industriale o urbano) consigliamo di pulire la superficie più spesso. E’ possibile rimuovere possibili macchie di ruggine con uno straccio e un po’ di lucidante. Questi prodotti sono disponibili in negozi fai da te, ma anche in negozi specializzati (come quelli che vendono i prodotti per pulire le macchine) che vendono vari “stainless steel polishers”.

WARRANTY

KEEP THIS AVAILABLE

1 PROOF OF PURCHASE / AANKOOP BEWIJS / PREUVE D'ACHAT / KAUFBELEG / JUSTIFICANTE DE COMPRA / PROVA D'ACQUISTO

2 SERIAL NUMBER / SERIENUMMER / NUMÉRO DE SÉRIE / SERIENNUMMER / NÚMERO DE SERIE / NUMERO DI SERIE

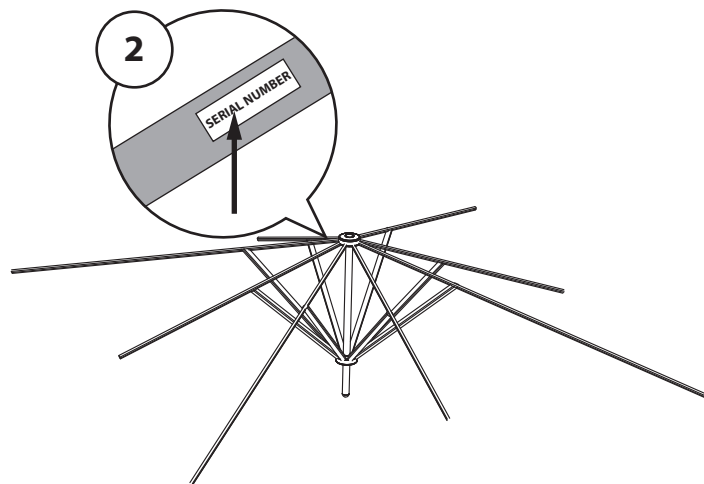
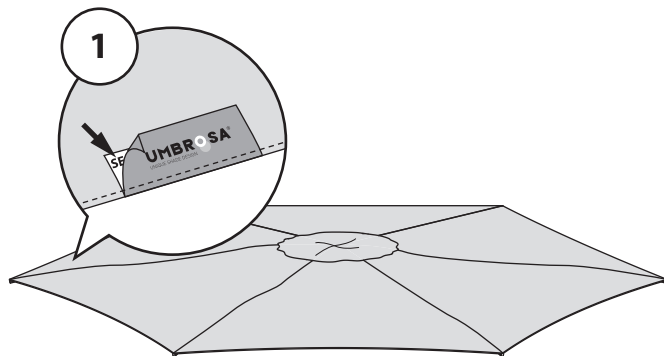

WWW.UMBROSA.COM

ENG	Warranty conditions on website
NL	Garantievoorwaarden op webpagina
FR	Conditions de garantie sur le site Web
DE	Garantiebedingungen auf der Webseite
ES	Condiciones de garantía en el sitio web
IT	Condizioni di garanzia sulla pagina web

SPARE PARTS

PARAFLEX CLASSIC HOLDER

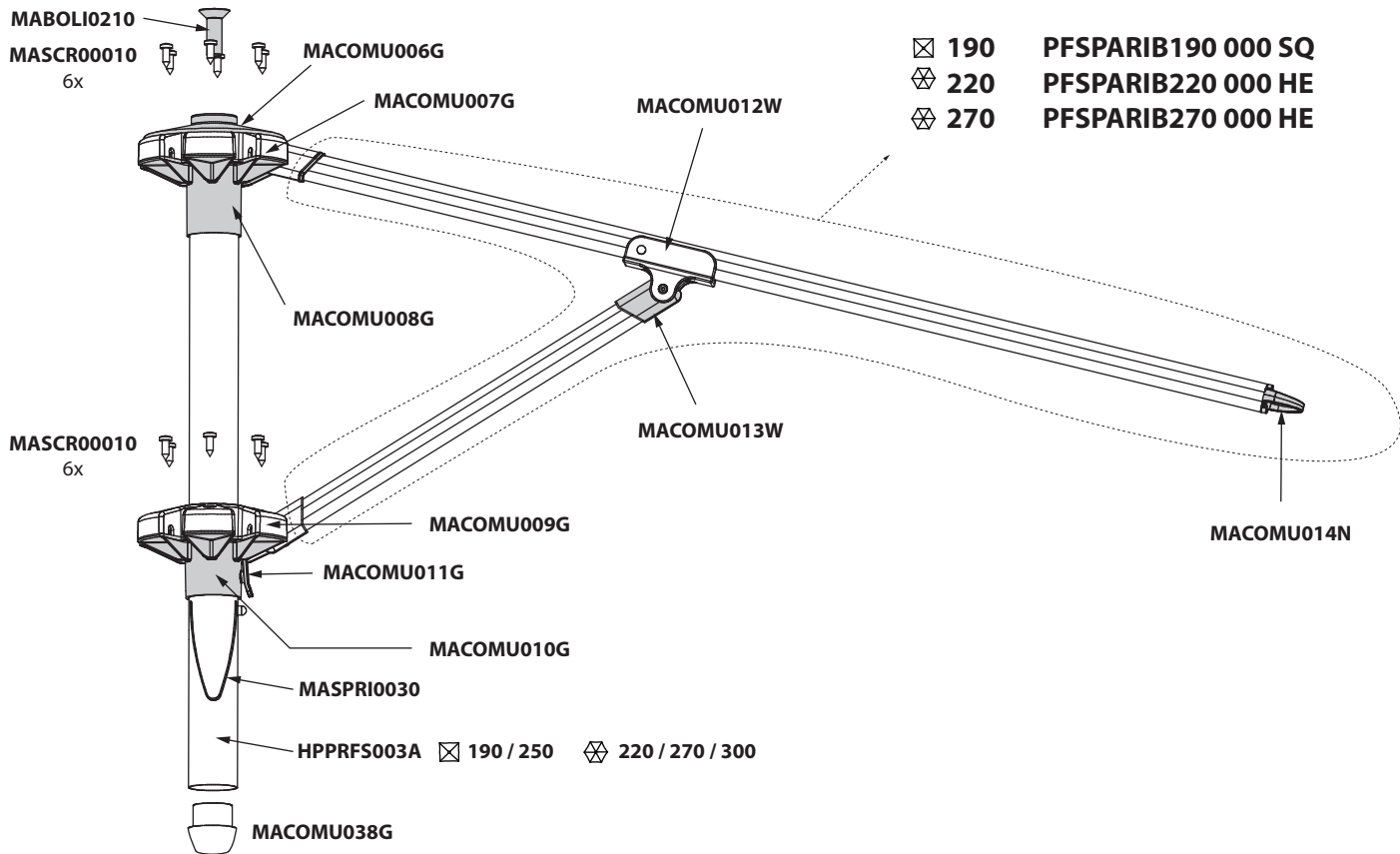

SPARE PARTS

PARAFLEX CLASSIC HOLDER

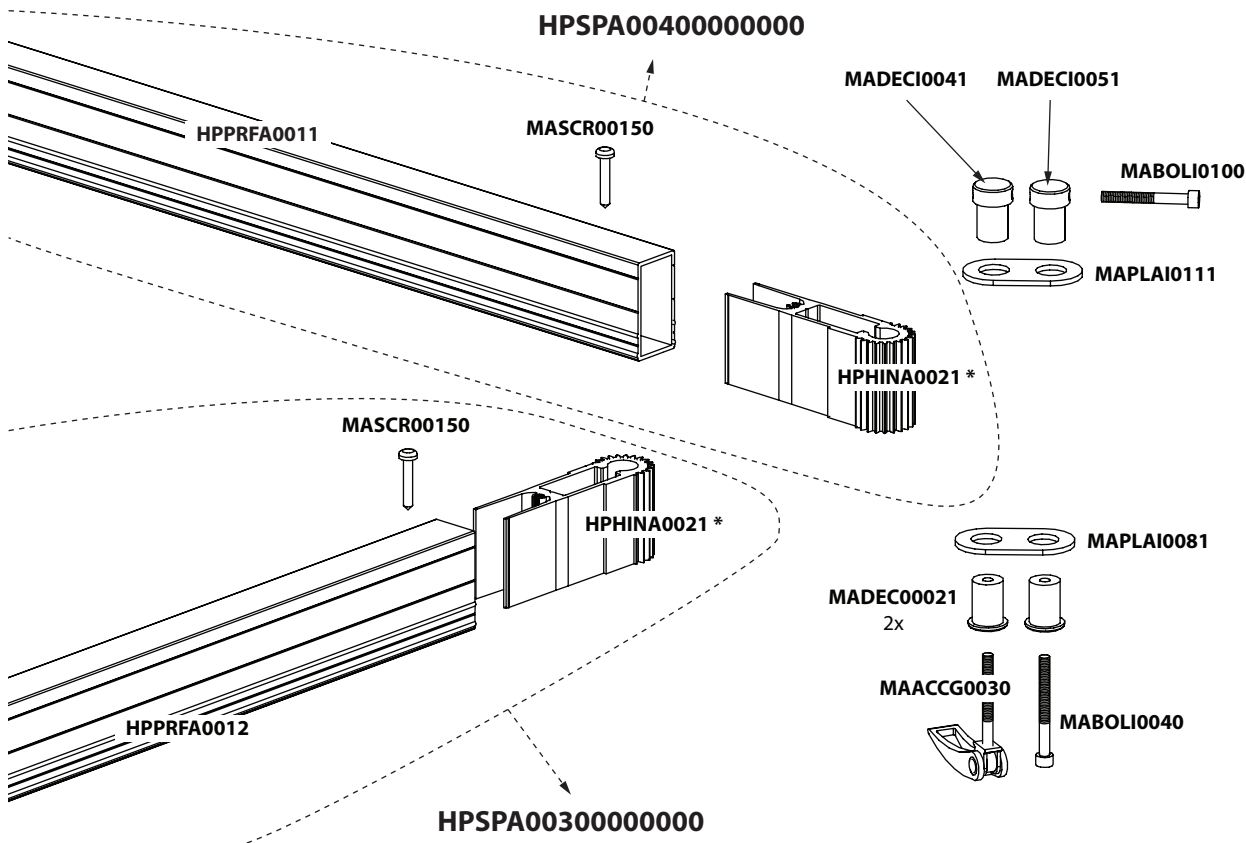

** This component is not replaceable, replace the subassembly instead*

SPARE PARTS

PARAFLEX CLASSIC HOLDER

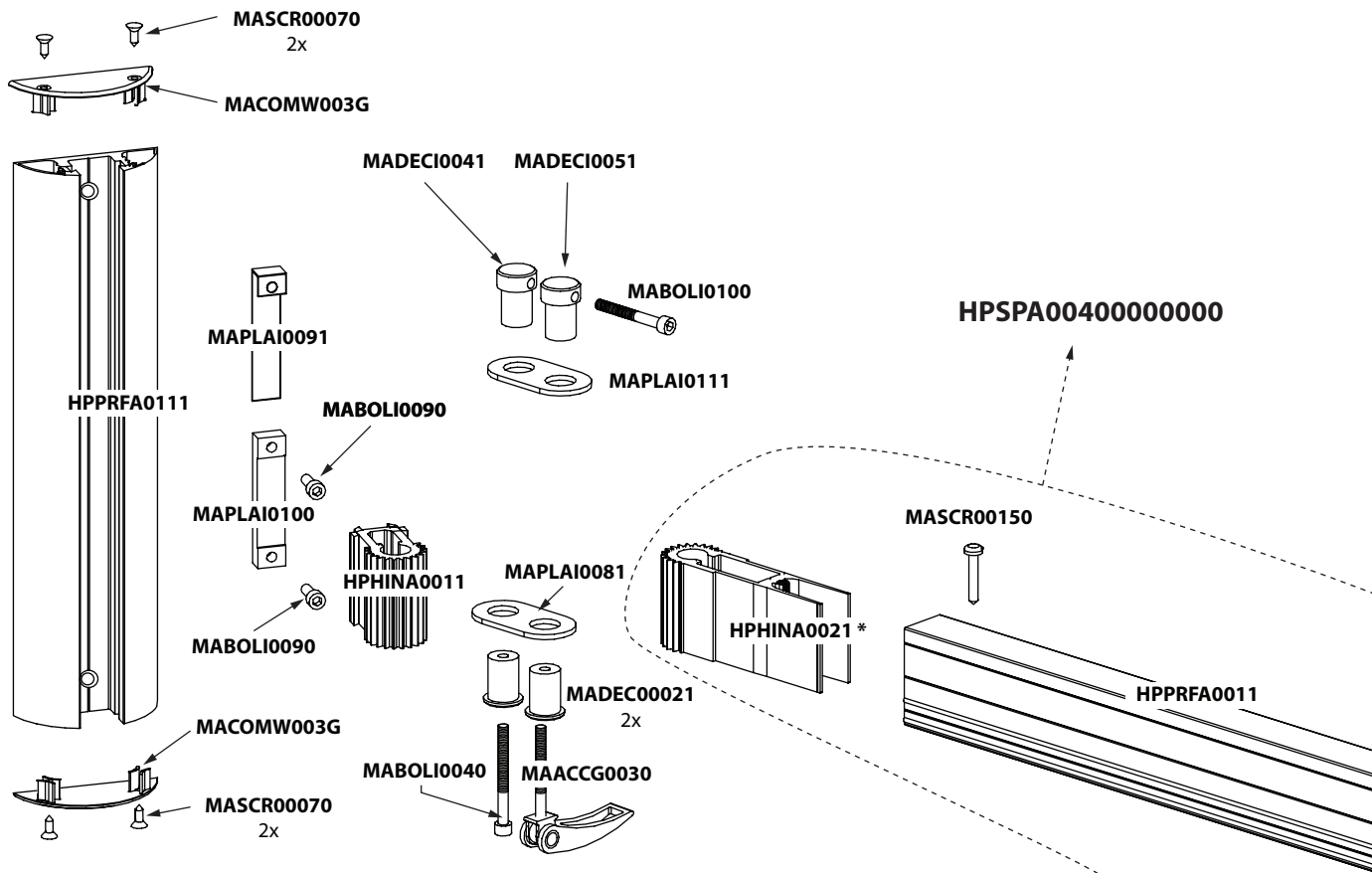

* This component is not replaceable, replace the subassembly instead

SPARE PARTS

PARAFLEX EVOLUTION HOLDER

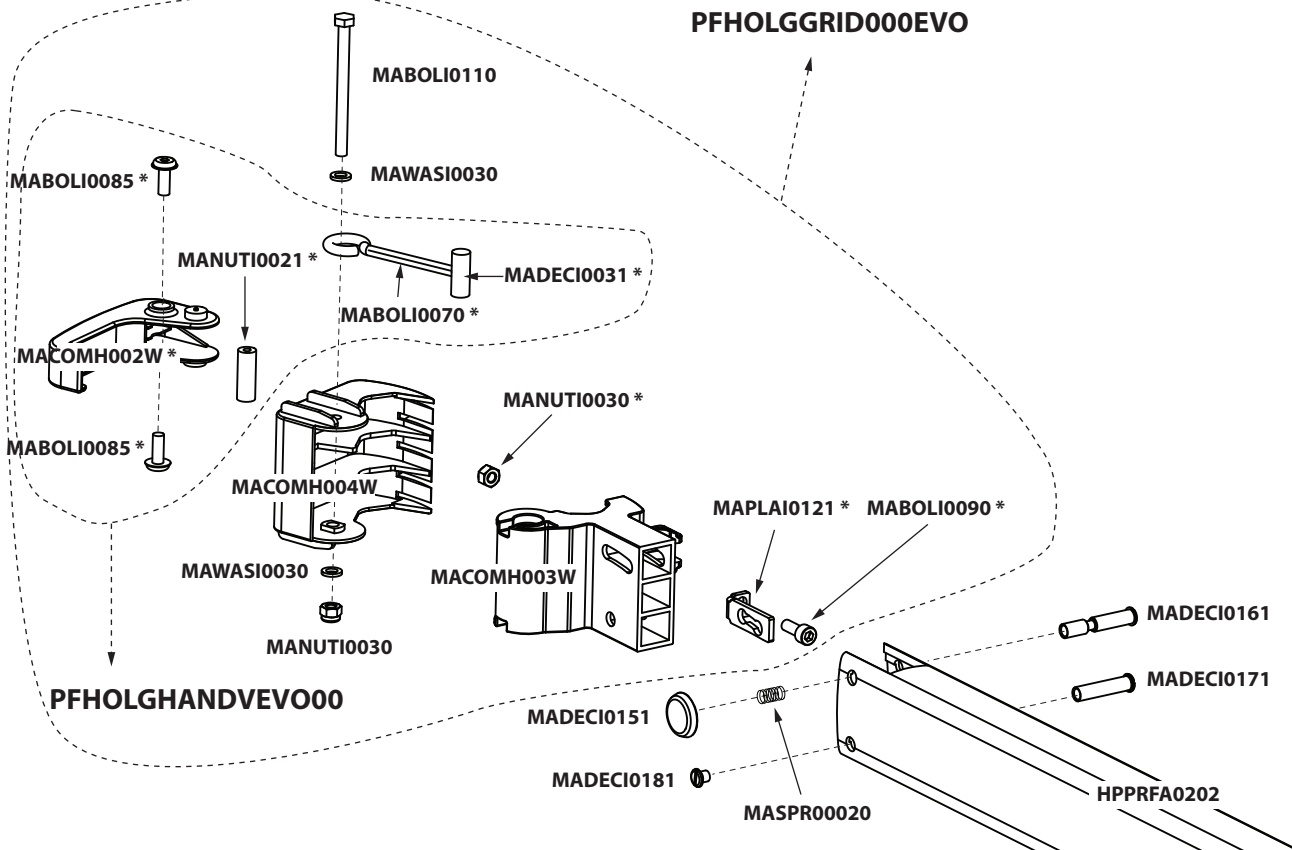

** This component is not replaceable, replace the subassembly instead*

SPARE PARTS

PARAFLEX EVOLUTION HOLDER

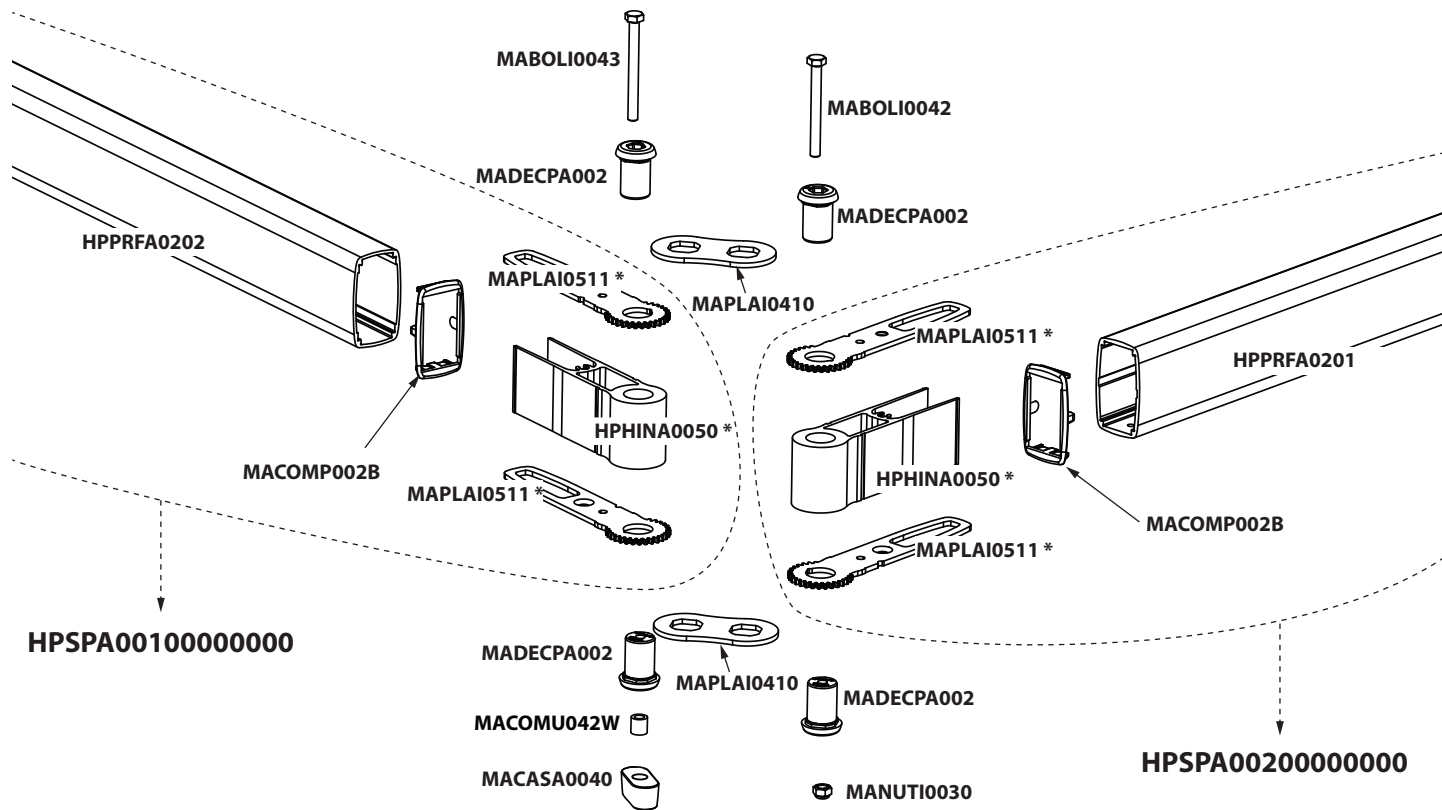

* This component is not replaceable, replace the subassembly instead

SPARE PARTS

PARAFLEX EVOLUTION HOLDER

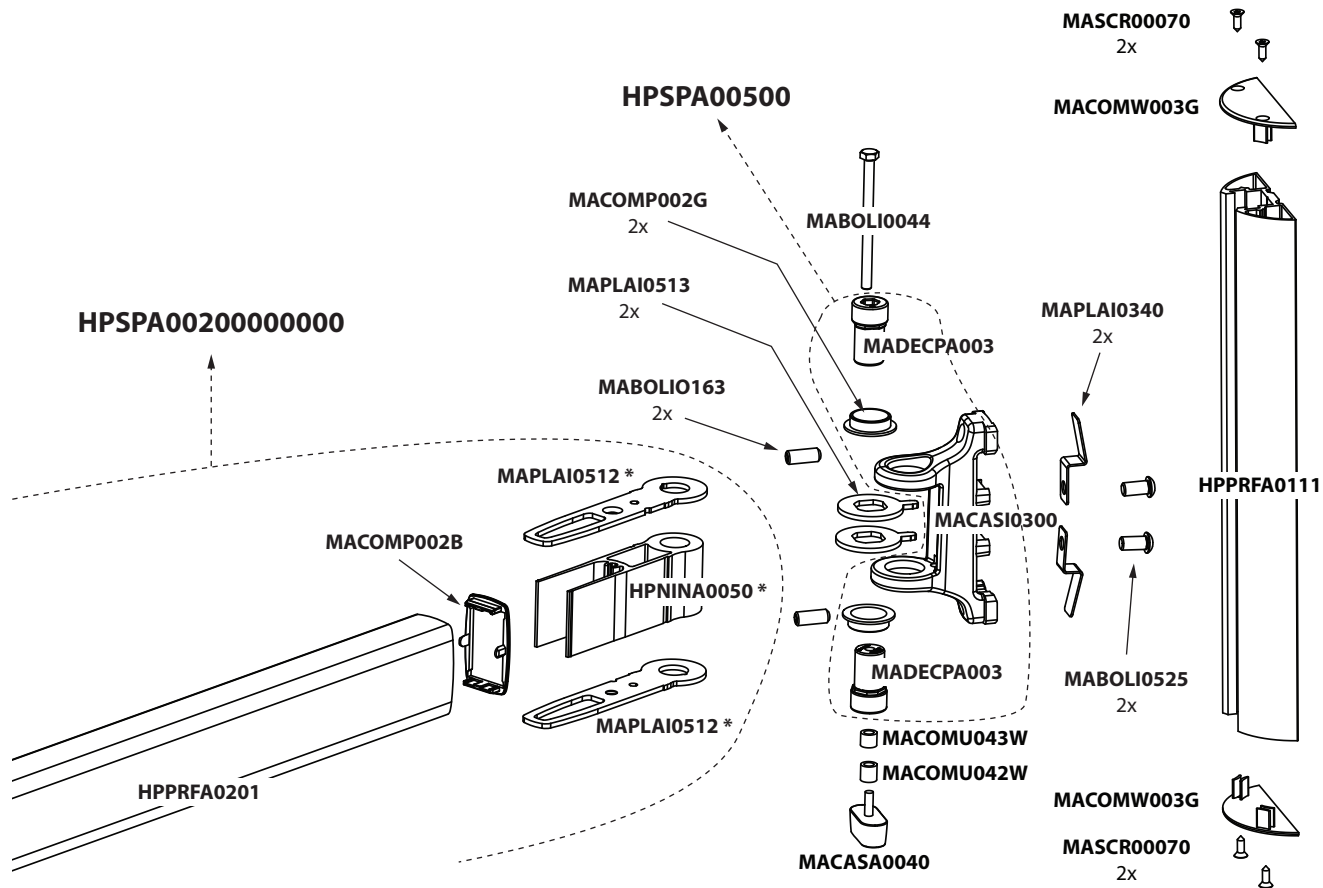

** This component is not replaceable, replace the subassembly instead*

UMBROSA

UNIQUE SHADE DESIGN

The content of this document, in particular the mentioned models, is protected by copyrights and/or design rights. The present document and its content is communicated to you for information purposes only. Any partial or total reproduction or any other use without our prior written permission is strictly prohibited. This technical sheet remains subject to possible changes. Of course we do our best to eliminate all mistakes, but Umbrosa is not responsible for the errors in the documentation of products. All measurements are approximate and are provided for informational purposes only.

Beversesteenweg 565 B, 8800 Roeselare, Belgium.
T: +32 51 30.22.60 | F: +32 51 30.22.62 | E: info@umbrosa.com | www.umbrosa.com

Version 191217