

PHZ

STOSSEN INTERNAL SHAPING

128

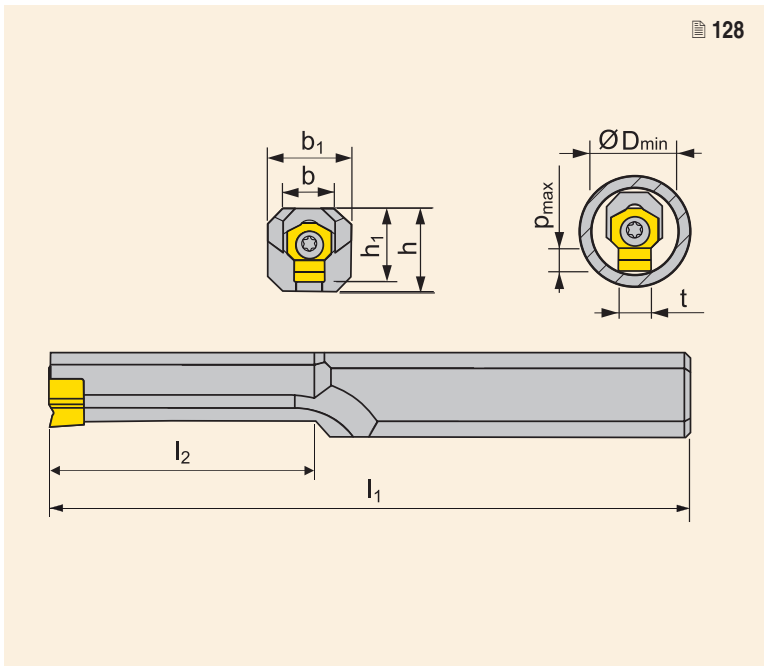

KLEMMHALTER ZUM STOSSEN / TOOLS FOR INTERNAL SHAPING

| ISO | Abmessungen / Dimensions | | | | | | | | | | kg | Ersatzteile Spare parts | WSP Inserts |
|----------------|--------------------------|----------------|----------------|------|----------------|----------------|-----|------------------|------------------|-----|------|----------------------------|-----------------|
| | h | h ₁ | b ₁ | b | l ₂ | l ₁ | t | D _{min} | p _{max} | | | | |
| PHZ 90 1104-06 | ● | 11,3 | 9 | 11,3 | 8,5 | 35 | 160 | 3 | 9,5 | 1,6 | 0,20 | SH21 | HZ90 0604-30 .. |
| PHZ 90 1107-06 | ● | 11,3 | 10 | 11,3 | 7 | 60 | 200 | 4 | 10,9 | 2,5 | 0,23 | SH21 | HZ90 0604-40 .. |
| PHZ 90 1111-06 | ● | 11,3 | 12 | 11,3 | - | 60 | 200 | 4 | 14 | 2,5 | 1,19 | SH21 | HZ90 0604-40 .. |
| | | | | | | | | 5 | 14 | 3 | | | |
| PHZ 1512-10 | ● | 15,5 | 16,2 | 12 | - | - | 220 | 6 | 17,8 | 4,2 | 0,40 | SH22 | HZ 1006-60 .. |
| | | | | | | | | 8 | 18,2 | 5,2 | | | |
| PHZ 2014-13 | ● | 20,6 | 21,5 | 14 | - | - | 250 | 10 | 24,2 | 6,2 | 0,65 | SH23 | HZ 1309-100 .. |
| | | | | | | | | 12 | 24,7 | 7,2 | | | |
| | | | | | | | | | | | | | |
| | | | | | | | | | | | | | |

Alle Abmessungen [mm] / All dimensions [mm]

ERSATZTEILE / SPARE PARTS

*) Empfohlene Torxschraube - siehe Seite 390-391 / See pages 390-391 for recommended screw torques

| Typ Type | Schraube* Screw* | Schraubendreher Screwdriver |
|-------------|---------------------|--------------------------------|
| SH21 | DVF 3593 | TX 207PLUS |
| SH22 | DVF 2260 | TX 215PLUS |
| SH23 | 5513 020-14 | TX 225PLUS |
| | | |
| | | |

HZ90

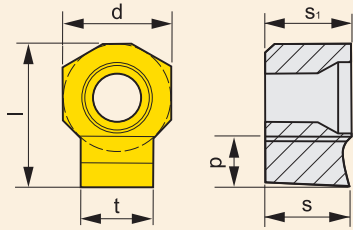

| Abmessungen Dimension | d | s | s ₁ | l | p | t |
|--------------------------|-------|------|----------------|-------|------|-------|
| 0604-30 | 6,00 | 4,66 | 4,76 | 7,50 | 1,60 | 3,00 |
| 0604-40 | 6,00 | 4,66 | 4,76 | 8,00 | 2,50 | 4,00 |
| 0604-50 | 6,00 | 4,66 | 4,76 | 8,00 | 3,00 | 5,00 |
| 1006-60 | 10,00 | 6,25 | 6,35 | 13,50 | 4,20 | 6,00 |
| 1006-80 | 10,00 | 6,25 | 6,35 | 13,50 | 5,20 | 8,00 |
| 1309-100 | 13,00 | 9,40 | 9,53 | 18,50 | 6,20 | 10,00 |
| 1309-120 | 13,00 | 9,40 | 9,53 | 18,50 | 7,20 | 12,00 |

Alle Abmessungen [mm] / All dimensions [mm]

| WSP Chip breaker | ISO | Sorten / Grades | | | | | | | | Breite Width | | Toleranz t Tolerance t | | Vorschub Infeed | |
|---------------------|------------------|-----------------|--|--|--|--|--|--|--|-----------------|--------|---------------------------|--------------------|--------------------|--|
| | | 333TN* | | | | | | | | t | min | max | a _{p min} | a _{p max} | |
| | HZ90 0604-30 C11 | ● | | | | | | | | 3,00 | 0,060 | 0,120 | 0,03 | 0,10 | |
| | HZ90 0604-40 C11 | ● | | | | | | | | 4,00 | 0,070 | 0,145 | 0,03 | 0,10 | |
| | HZ90 0604-50 C11 | ● | | | | | | | | 5,00 | 0,070 | 0,145 | 0,03 | 0,10 | |
| | HZ 1006-60 C11 | ● | | | | | | | | 6,00 | 0,070 | 0,145 | 0,03 | 0,15 | |
| | HZ 1006-80 C11 | ● | | | | | | | | 8,00 | 0,080 | 0,170 | 0,03 | 0,15 | |
| | HZ 1309-100 C11 | ● | | | | | | | | 10,00 | 0,080 | 0,170 | 0,05 | 0,20 | |
| | HZ 1309-120 C11 | ● | | | | | | | | 12,00 | 0,095 | 0,205 | 0,05 | 0,20 | |
| | HZ90 0604-30 D10 | ● | | | | | | | | 3,00 | 0,020 | 0,060 | 0,03 | 0,10 | |
| | HZ90 0604-40 D10 | ● | | | | | | | | 4,00 | 0,030 | 0,078 | 0,03 | 0,10 | |
| | HZ90 0604-50 D10 | ● | | | | | | | | 5,00 | 0,030 | 0,078 | 0,03 | 0,10 | |
| | HZ 1006-60 D10 | ● | | | | | | | | 6,00 | 0,030 | 0,078 | 0,03 | 0,15 | |
| | HZ 1006-80 D10 | ● | | | | | | | | 8,00 | 0,040 | 0,098 | 0,03 | 0,15 | |
| | HZ 1309-100 D10 | ● | | | | | | | | 10,00 | 0,040 | 0,098 | 0,05 | 0,20 | |
| | HZ 1309-120 D10 | ● | | | | | | | | 12,00 | 0,050 | 0,120 | 0,05 | 0,20 | |
| | HZ90 0604-30 H7 | ● | | | | | | | | 3,00 | 0,000 | 0,010 | 0,03 | 0,10 | |
| | HZ90 0604-40 H7 | ● | | | | | | | | 4,00 | 0,000 | 0,012 | 0,03 | 0,10 | |
| | HZ90 0604-50 H7 | ● | | | | | | | | 5,00 | 0,000 | 0,012 | 0,03 | 0,10 | |
| | HZ 1006-60 H7 | ● | | | | | | | | 6,00 | 0,000 | 0,012 | 0,03 | 0,15 | |
| | HZ 1006-80 H7 | ● | | | | | | | | 8,00 | 0,000 | 0,015 | 0,03 | 0,15 | |
| | HZ 1309-100 H7 | ● | | | | | | | | 10,00 | 0,000 | 0,015 | 0,05 | 0,20 | |
| | HZ 1309-120 H7 | ● | | | | | | | | 12,00 | 0,000 | 0,018 | 0,05 | 0,20 | |
| | HZ90 0604-30 P9 | ● | | | | | | | | 3,00 | -0,031 | -0,006 | 0,03 | 0,10 | |
| | HZ90 0604-40 P9 | ● | | | | | | | | 4,00 | -0,042 | -0,012 | 0,03 | 0,10 | |
| | HZ90 0604-50 P9 | ● | | | | | | | | 5,00 | -0,042 | -0,012 | 0,05 | 0,10 | |
| | HZ 1006-60 P9 | ● | | | | | | | | 6,00 | -0,042 | -0,012 | 0,03 | 0,15 | |
| | HZ 1006-80 P9 | ● | | | | | | | | 8,00 | -0,051 | -0,015 | 0,03 | 0,15 | |
| | HZ 1309-100 P9 | ● | | | | | | | | 10,00 | -0,051 | -0,015 | 0,05 | 0,20 | |
| | HZ 1309-120 P9 | ● | | | | | | | | 12,00 | -0,061 | -0,018 | 0,05 | 0,20 | |

* Sorte 333TN = HSS + beschichtet PVD / Grade 333TN = HSS + PVD coating

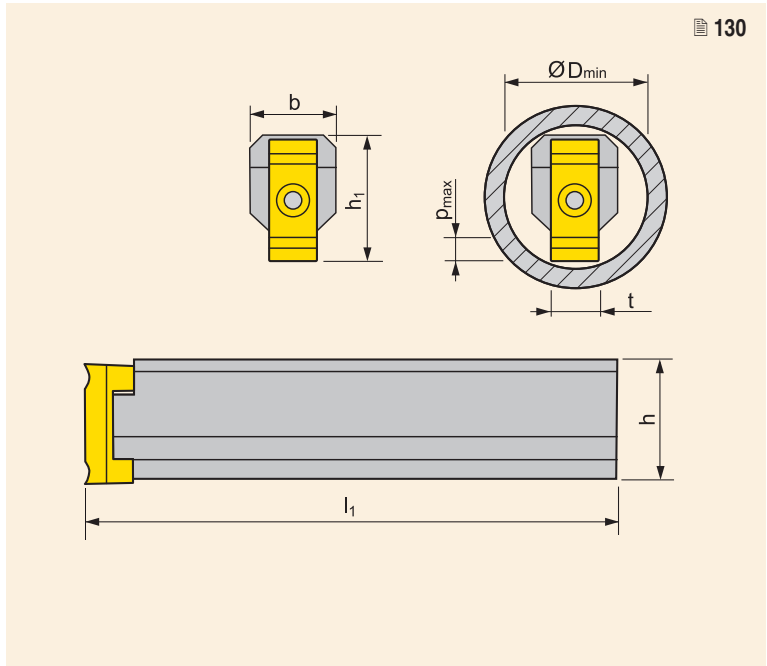
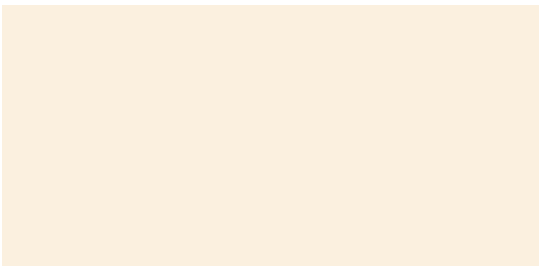
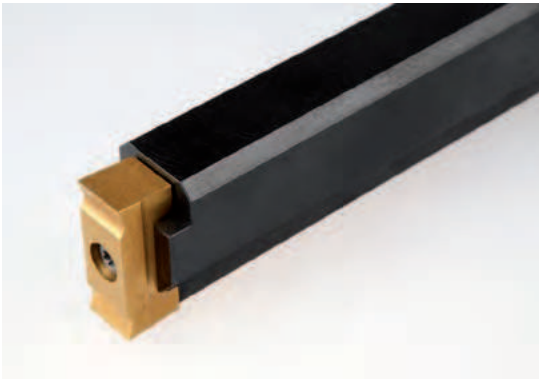

130

KLEMMHALTER ZUM STOSSEN / TOOLS FOR INTERNAL SHAPING

| ISO | Abmessungen / Dimensions | | | | | | | | kg | Ersatzteile Spare parts | WSP Inserts |
|---------------|--------------------------|----------------|------|----------------|-----|------------------|------------------|----|------|----------------------------|----------------|
| | h | h ₁ | b | l ₁ | t | D _{min} | p _{max} | | | | |
| PHZ/2 3625-14 | ● | 36 | 37,5 | 25 | 300 | 14 | 44 | 8 | 0,88 | SH23 | HZ/2 14-14 .. |
| | | | | | | 16 | 44 | 9 | | | HZ/2 16-16 .. |
| PHZ/2 4832-18 | ● | 48 | 50 | 32 | 400 | 18 | 58 | 12 | 2,00 | SH24 | HZ/2 18-18 .. |
| | | | | | | 20 | 58 | 13 | | | HZ/2 20-20 .. |
| | | | | | | | | | | | |
| | | | | | | | | | | | |
| | | | | | | | | | | | |
| | | | | | | | | | | | |
| | | | | | | | | | | | |
| | | | | | | | | | | | |
| | | | | | | | | | | | |

Alle Abmessungen [mm] / All dimensions [mm]

ERSATZTEILE / SPARE PARTS

*) Empfohlene Torxschraube - siehe Seite 390-391 / See pages 390-391 for recommended screw torques

| Typ Type | Schraube* Screw* | Schraubendreher Screwdriver | | | | | |
|-------------|---------------------|--------------------------------|--|--|--|--|--|
| SH23 | 5513 020-14 | TX 225PLUS | | | | | |
| SH24 | 5513 021-03 | DMN 3124 | | | | | |
| | | | | | | | |
| | | | | | | | |
| | | | | | | | |

ISO D
ISO D
ISO P
ISO P
ISO M
ISO M
ISO S
ISO S
SONSTIGE
OTHER
ABSTECHEIN, EINSTECHEIN
PARTING, GROOVING
GEWINDEDREHEN
THREADING
WENDESCHNEIDPLATTEN
INSERTS

HZ-2

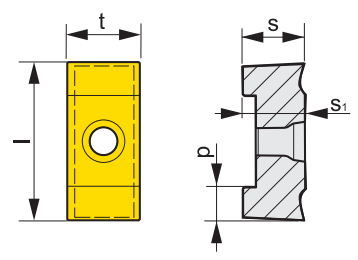

| Abmessungen Dimension | s | s ₁ | l | p | t |
|--------------------------|-------|----------------|-------|-------|-------|
| 14-1 | 13,90 | 14,00 | 36,00 | 8,00 | 14,00 |
| 16-1 | 13,90 | 14,00 | 36,00 | 9,00 | 16,00 |
| 18-1 | 15,90 | 16,00 | 45,00 | 12,00 | 18,00 |
| 20-2 | 15,90 | 16,00 | 45,00 | 13,00 | 20,00 |

Alle Abmessungen [mm] / All dimensions [mm]

| WPS Chip breaker | ISO | 333TN* | Sorten / Grades | | | | | | | Breite Width | | Toleranz t Tolerance t | | Vorschub Infeed | |
|---------------------|----------------|--------|-----------------|--|--|--|--|--|--|-----------------|--|---------------------------|--------|--------------------|--------------------|
| | | | | | | | | | | t | | min | max | a _{p min} | a _{p max} |
| | HZ/2 14-14 C11 | ● | | | | | | | | 14,00 | | 0,095 | 0,205 | 0,08 | 0,30 |
| | HZ/2 16-16 C11 | ● | | | | | | | | 16,00 | | 0,095 | 0,205 | 0,08 | 0,30 |
| | HZ/2 18-18 C11 | ● | | | | | | | | 18,00 | | 0,095 | 0,205 | 0,09 | 0,35 |
| | HZ/2 20-20 C11 | ● | | | | | | | | 20,00 | | 0,110 | 0,240 | 0,09 | 0,35 |
| | HZ/2 14-14 H7 | ● | | | | | | | | 14,00 | | 0,000 | 0,018 | 0,08 | 0,30 |
| | HZ/2 16-16 H7 | ● | | | | | | | | 16,00 | | 0,000 | 0,018 | 0,08 | 0,30 |
| | HZ/2 18-18 H7 | ● | | | | | | | | 18,00 | | 0,000 | 0,018 | 0,09 | 0,35 |
| | HZ/2 20-20 H7 | ● | | | | | | | | 20,00 | | 0,000 | 0,021 | 0,09 | 0,35 |
| | HZ/2 14-14 P9 | ○ | | | | | | | | 14,00 | | -0,061 | -0,018 | 0,08 | 0,30 |
| | HZ/2 16-16 P9 | ○ | | | | | | | | 16,00 | | -0,061 | -0,018 | 0,09 | 0,35 |
| | HZ/2 18-18 P9 | ○ | | | | | | | | 18,00 | | -0,061 | -0,018 | 0,10 | 0,40 |
| | HZ/2 20-20 P9 | ○ | | | | | | | | 20,00 | | -0,074 | -0,022 | 0,10 | 0,45 |

* Sorte 333TN = HSS + beschichtet PVD / Grade 333TN = HSS + PVD coating



● Lagertortiment / ○ Kein Lagertortiment ■ Lagertortiment ab 1.4.2014 / □ Kein Lagertortiment ab 1.4.2014
 ● stocked as standard / ○ not stocked as standard, ■ stocked as standard from 1.4.2014 / □ not stocked as standard from 1.4.2014
 Derzeitiges Lagerbestandssortiment ist abhängig von der gültigen Preisliste. / See price list for current availability.