

BRAZED TOOLS HM-GELÖTETE WERKZEUGE

Technical information **A270**
Technische Auskünfte

Applications index **A271**
Anwendungen

Toolholders **A272-274**
Drehmeißel

Boring bars **A275-276**
Innendrehmeißel

Uncoated inserts / Unbeschichtete Sorten

KM15

Finishing grade in the K10 range. This carbide grade is for use on cast iron, aluminium and heat-resistant alloys. This grade works well on cobalt based alloys and synthetic materials and is suitable for finishing on heat-resistant alloys.

Es ist eine Sorte zum Schlichten, im K10 Bereich. Diese Sorte ist für Guß, Aluminium und hitzebeständige Legierungen geeignet. Es hat gute Bearbeitungseigenschaften für Kobaltlegierungen und synthetische Materialien und ist für Schlichten in hitzebeständigen Legierungen besonders gut geeignet.

PM25

General purpose uncoated grade in the P30 range. This tough, economical grade is suitable for the machining of carbon steels, alloyed steels, tool steels and stainless steels.

PM25 provides toughness and resistance to deformation in roughing and semi-finishing operations.

Eine allgemeine unbeschichtete Sorte im P30 Bereich. Diese zähe und wirtschaftliche Sorte ist zur Bearbeitung von Kohlenstoffstahl, legiertem Stahl, Werkzeugstahl und rostfreiem Stahl gut geeignet.

PM25 hat eine gute Zähigkeit und Verschleißfestigkeit für Schrupp- und mittlere Schlichtarbeiten.

Grinding / Schleifen

In order to obtain a satisfactory result, it is necessary to have a steady grinding table or holder that can be set to the required angle by means of a graduated scale and by non-vibrating small spindles.

Rough grinding is normally carried out using a silicon carbide grinding wheel. The finish grind or lapping must always be made using a diamond wheel.

Longer life of the cutting edge and less breakage justify the increased cost of correct grinding.

The grinding wheel must be kept clean to ensure that cutting capacity is maintained.

Whenever possible, always grind perpendicular to the cutting edge.

Um ein erfolgreiches Ergebnis zu bekommen, braucht man stabile Auflagetische oder Halter, die man mit Hilfe eines Gradmessers im gewünschten Winkel einstellen kann, sowie schwingungsfreie Spindeln.

Zum Grobschleifen kann man eine Siliziumkarbidscheibe verwenden. Aber zum Feinschleifen und Lappen muß man immer eine Diamantscheibe verwenden. Längere Standzeit der Schneiden und wenige Kantenausbrüche gleichen die höheren Kosten von einem korrekten Schleifen aus.

Die Schleifscheibe muß man sauber halten, denn das beeinflusst wesentlich die Schneidleistung.

Wenn möglich, immer gegen die Schneidkante schleifen.

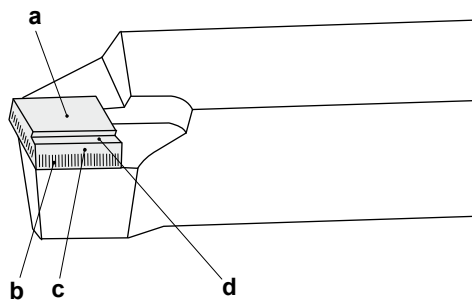

- a.- Top face / Spanflächen
- b.- Secondary clearances / Freiflächen
- c.- Lapped primary clearances / Läppfasen
- d.- Chipbreaker groove / Spanleitstufe

Toolholders Drehmeißel

ISO 2 45°

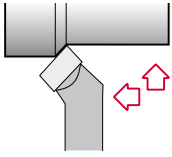

Page
Seite A272

ISO 6 90°

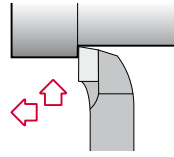

Page
Seite A272

ISO 7 90°

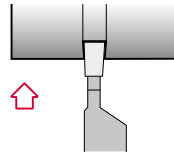

Page
Seite A273

ISO 351 80°

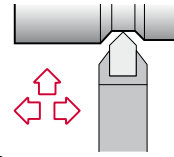

Page
Seite A273

UI 30 60°

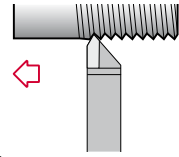

Page
Seite A274

Boring bars Innendrehmeißel

ISO 9 90°

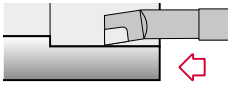

Page
Seite A275

UI 40 60°

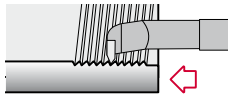

Page
Seite A275

UI 50 90°

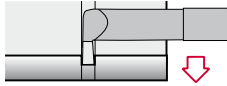

Page
Seite A276

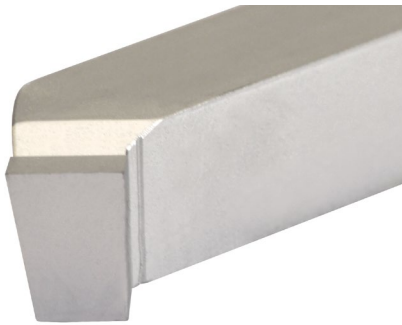

Characteristics:
Brazed toolholder.
DIN 4972

Eigenschaften:
HM-Gelöteter Drehmeißel.

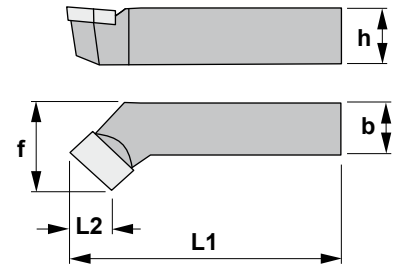
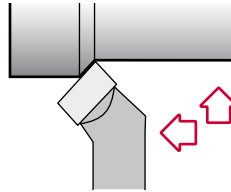

ISO 2 45°

Reference Bezeichnung	h	b	L1	L2	f	Insert size Wendeschnidplatte		KM15	PM25
ISO2 1010 R	10	10	90	8	14	C8	0,070	<input type="radio"/>	<input type="radio"/>
ISO2 1010 L	10	10	90	8	14	C8	0,070	<input type="radio"/>	<input type="radio"/>
ISO2 1212 R	12	12	100	10	17	ABC10	0,100	<input type="radio"/>	<input checked="" type="radio"/>
ISO2 1212 L	12	12	100	10	17	ABC10	0,100	<input type="radio"/>	<input checked="" type="radio"/>
ISO2 1616 R	16	16	110	12	22	ABC12	0,200	<input checked="" type="radio"/>	<input checked="" type="radio"/>
ISO2 1616 L	16	16	110	12	22	ABC12	0,200	<input checked="" type="radio"/>	<input checked="" type="radio"/>
ISO2 2020 R	20	20	125	16	28	ABC16	0,400	<input checked="" type="radio"/>	<input checked="" type="radio"/>
ISO2 2020 L	20	20	125	16	28	ABC16	0,400	<input checked="" type="radio"/>	<input checked="" type="radio"/>
ISO2 2525 R	25	25	140	20	35	ABC20	0,650	<input checked="" type="radio"/>	<input checked="" type="radio"/>
ISO2 2525 L	25	25	140	20	35	ABC20	0,650	<input checked="" type="radio"/>	<input checked="" type="radio"/>



Characteristics:
Brazed toolholder.
DIN 4980

Eigenschaften:
HM-Gelöteter Drehmeißel.

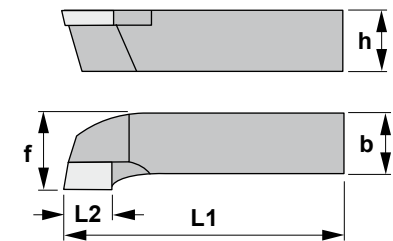
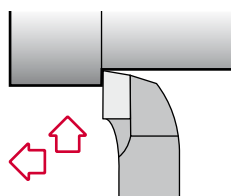

i AVAILABILITY / VERFÜGBARKEIT

- Standard item / Standard-Artikel
- Check availability / Verfügbarkeit prüfen

ISO 6 90°

Reference Bezeichnung	h	b	L1	L2	f	Insert size Wendeschnidplatte		KM15	PM25
ISO6 1010 R	10	10	90	8	14	C8	0,070	<input type="radio"/>	<input type="radio"/>
ISO6 1010 L	10	10	90	8	14	C8	0,070	<input type="radio"/>	<input type="radio"/>
ISO6 1212 R	12	12	100	10	17	ABC10	0,100	<input type="radio"/>	<input checked="" type="radio"/>
ISO6 1212 L	12	12	100	10	17	ABC10	0,100	<input type="radio"/>	<input checked="" type="radio"/>
ISO6 1616 R	16	16	110	12	22	ABC12	0,200	<input checked="" type="radio"/>	<input checked="" type="radio"/>
ISO6 1616 L	16	16	110	12	22	ABC12	0,200	<input checked="" type="radio"/>	<input checked="" type="radio"/>
ISO6 2020 R	20	20	125	16	28	ABC16	0,400	<input checked="" type="radio"/>	<input checked="" type="radio"/>
ISO6 2020 L	20	20	125	16	28	ABC16	0,400	<input checked="" type="radio"/>	<input checked="" type="radio"/>
ISO6 2525 R	25	25	140	20	35	ABC20	0,650	<input checked="" type="radio"/>	<input checked="" type="radio"/>
ISO6 2525 L	25	25	140	20	35	ABC20	0,650	<input checked="" type="radio"/>	<input checked="" type="radio"/>

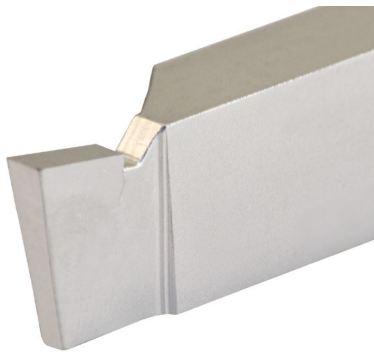

Characteristics:
Brazed toolholder.
DIN 4981

Eigenschaften:
HM-Gelöteter Drehmeißel.

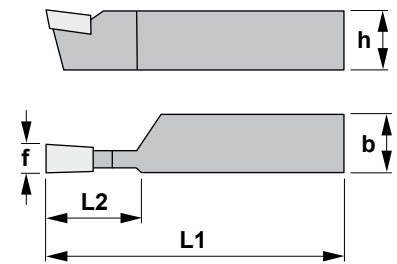
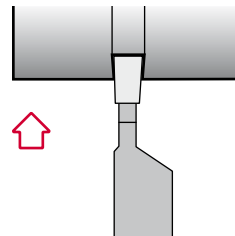

ISO 7 90°

Reference Bezeichnung	h	b	L1	L2	f	Insert size Wendeschneidplatte		KM15	PM25
ISO7 1208 R	12	08	100	12	3	D3	0,070	○	●
ISO7 1208 L	12	08	100	12	3	D3	0,070	○	●
ISO7 1610 R	16	10	110	14	4	D4	0,150	●	●
ISO7 1610 L	16	10	110	14	4	D4	0,150	●	●
ISO7 2012 R	20	12	125	16	5	D5	0,200	●	●
ISO7 2012 L	20	12	125	16	5	D5	0,200	●	●
ISO7 2516 R	25	16	140	20	6	D6	0,400	●	●
ISO7 2516 L	25	16	140	20	6	D6	0,400	●	●
ISO7 3220 R	32	20	170	25	8	D8	0,750	●	●
ISO7 3220 L	32	20	170	25	8	D8	0,750	●	●

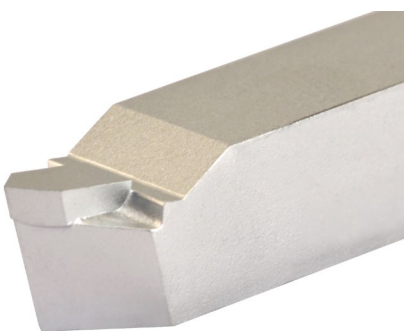

Characteristics:
Brazed toolholder.
DIN 4975

Eigenschaften:
HM-Gelöteter Drehmeißel.

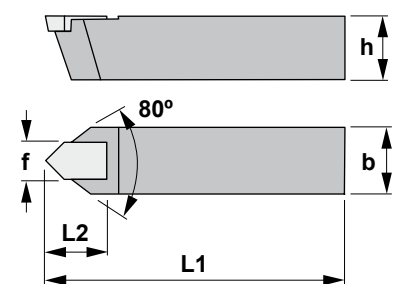
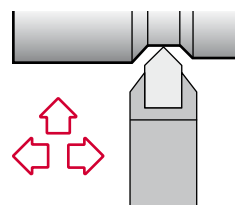

ISO 351 80°

Reference Bezeichnung	h	b	L1	L2	f	Insert size Wendeschneidplatte		KM15	PM25
ISO351 1212 N	12	12	100	10	5	E5	0,100	○	○
ISO351 1616 N	16	16	110	12	6	E6	0,200	○	○
ISO351 2020 N	20	20	125	16	8	E8	0,400	○	○
ISO351 2525 N	25	25	140	18	10	E10	0,650	○	○

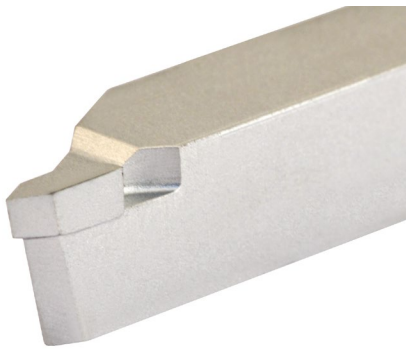

Characteristics:
Brazed toolholder.
ISO 352

Eigenschaften:
HM-Gelöteter Drehmeißel.

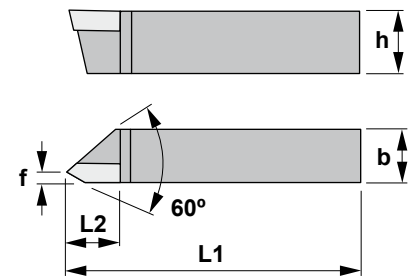
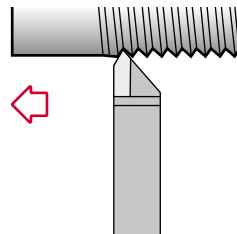

UI 30 60°

Reference Bezeichnung	h	b	L1	L2	f	Insert size Wendeschneidplatte	⚖️ kg	KM15	PM25
UI 30 60° 1212 R	12	12	100	12	1,8	E5	0,100	●	●
UI 30 60° 1616 R	16	16	110	14	2,0	E6	0,200	●	●
UI 30 60° 2020 R	20	20	125	16	2,5	E8	0,350	●	●
UI 30 60° 2525 R	25	25	140	18	3,0	E10	0,600	●	●



Characteristics:
Brazed boring bar.
UNI 4111

Eigenschaften:
HM-Gelöteter Innendrehmeißel.

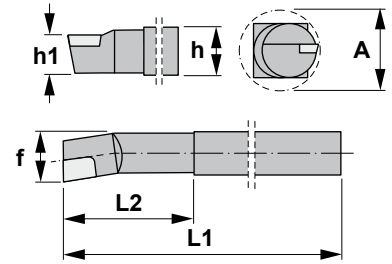
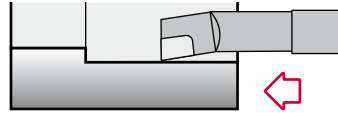

ISO 9 90°

Reference Bezeichnung	h=b	h1	L	b2	L2	f	A	Insert size Wendeschneidplatte		KM15	PM25
ISO9 0808 R	8	6,4	125	3,1	40	11	14	C7	0,060	●	●
ISO9 1010 R	10	8,0	150	4,0	50	14	18	C7	0,100	●	●
ISO9 1212 R	12	9,6	180	5,1	63	17	21	C8	0,250	●	●
ISO9 1616 R	16	12,8	210	6,2	80	22	27	ABC 10	0,400	●	●
ISO9 2020 R	20	16,0	250	8,3	100	28	34	ABC 12	0,700	●	●
ISO9 2525 R	25	20,0	300	10,0	125	35	43	ABC 16	1,300	●	●
ISO9 3232 R	32	25,6	355	12,0	160	44	52	ABC 20	2,500	●	●

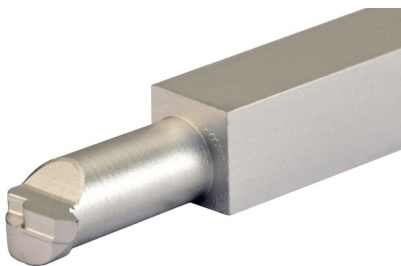

Characteristics:
Brazed boring bar.
ISO 353

Eigenschaften:
HM-Gelöteter
Innendrehmeißel.

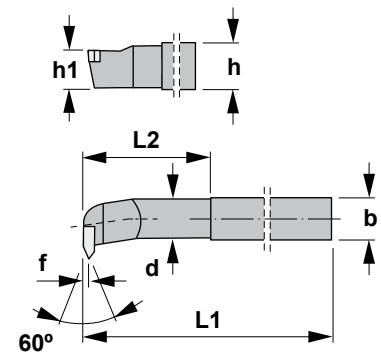
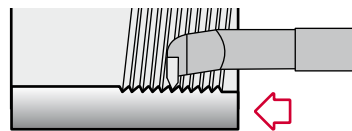

i AVAILABILITY / VERFÜGBARKEIT
 ● Standard item / Standard-Artikel
 ○ Check availability / Verfügbarkeit prüfen

UI 40 60°

Reference Bezeichnung	d	h=b	L	L2	f	Insert size Wendeschneidplatte		KM15	PM25
UI 40 60° 1010 R	10	10	100	26	1,8	E4	0,070	●	●
UI 40 60° 1212 R	12	12	110	26	1,8	E4	0,200	●	●
UI 40 60° 1616 R	16	16	140	33	2,0	E5	0,250	●	●
UI 40 60° 2020 R	20	20	160	41	2,0	E6	0,450	●	●
UI 40 60° 2525 R	25	25	180	49	2,5	E8	0,750	●	●

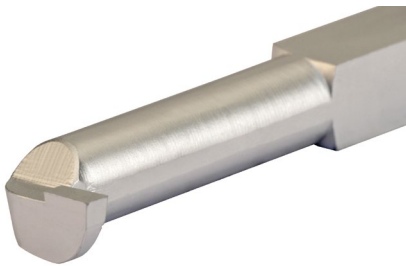

Characteristics:
Brazed boring bar.
ISO 354

Eigenschaften:
HM-Gelöteter Innendrehmeißel.

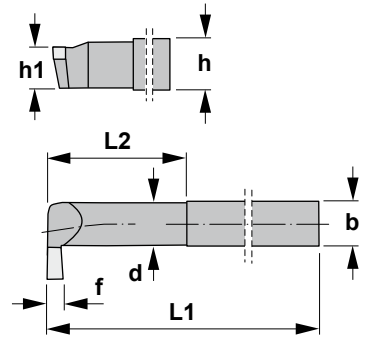
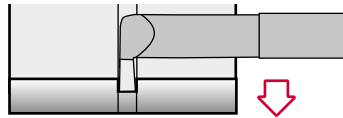

UI 50 90°

Reference Bezeichnung	d	h=b	L	L2	f	Insert size Wendeschneidplatte		KM15	PM25
UI 50 90° 1010 R	10	10	140	52	3	D3	0,100	●	●
UI 50 90° 1212 R	12	12	160	56	4	D4	0,200	●	●
UI 50 90° 1616 R	16	16	180	63	5	D5	0,350	●	●
UI 50 90° 2020 R	20	20	210	80	6	D6	0,700	●	●
UI 50 90° 2525 R	25	25	250	100	8	D8	1,250	●	●