

Model 400SC TELESCOPIC BOOM LIFT



ENVIRONMENTALLY FRIENDLY

- Variable speed engine control for improved fuel efficiency reducing operation cost.

POWER AND PERFORMANCE

- Dual capacity 270 kg unrestricted and 450 kg restricted allowing you to carry more tools or materials to stay on a job longer.

MORE ACCESS

- 360 degrees continuous rotation for an increased work envelope.
- Track mounted for easier manoeuvring through muddy environments.

GREATER STRENGTH

- Dura Tough hood material highly impact resistant, resulting in less maintenance and greater protection for sensitive components.

Standard Features

- 0.91 m x 1.83 m low mount platform
- Side entry with drop bar mid rail
- Multiple function operation
- Full proportional drive joystick control with integral thumb steer switch
- Full proportional main boom and swing joystick control
- Multiple speed control for telescope and platform rotate
- Selectable creep speed on drive / lift and swing functions
- 180 degree powered platform rotator
- Platform console machine status light panel 1
- Load sensing system
- AC cable to platform
- Deutz D2.3 L3 (36.4 kW) diesel engine
- Engine distress warning/shut down system 2
- Dura Tough turntable hoods
- Swing-out engine tray
- Control ADE[®] - Advanced Design Electronics System
- Hydrostatic drive transmission
- Horn
- 5 degree tilt alarm and indicator light
- 0.40 m x 2.77 m x 0.55 m rubber tracks
- Lifting/tie down lugs
- Hour meter
- Ground control selector switch with key lock
- Platform tool tray
- 12V DC auxiliary power

Standard Specifications

Power Source	
• Diesel Engine	
Deutz D2.3 L3 Stage IIIA	36.4 kW
• Fuel Tank Capacity	83 L

Hydraulic Reservoir	
• Hydraulic Reservoir	136 L
• Auxiliary Power	12V-DC

Accessories & Options

- 0.91 m x 2.44 m low mount platform
- Side entry with inward swing gate
- 13 mm air line to platform
- On-board 4,000 W generator
- SkyPower[®] package 7,500 watt on-board generator
- SkyWelder[®] package 250 amp welder in the platform 3
- Nite-Bright[®] package 4
- All motion alarm
- Light package 5
- Platform worklights
- Head and tail lights
- Flashing amber beacon
- Plugs & Sockets
- Hostile environment package 6
- Hydraulic oil cooler
- Catalytic Purifier Muffler
- Skyguard with beacon
- Skyguard without beacon
- Soft Touch Proximity System
- Corner storage tray

Note: Some options may increase lead time, and some option combinations may not be available.

Model 400SC

TELESCOPIC BOOM LIFT

Performance

- Platform Height 12.14 m
- Working Height 14.14 m
- Horizontal Outreach 10.00 m
- Working Outreach 10.65 m
- Swing 360 Degrees Continuous
- Platform Capacity
 - Restricted 450 kg
 - Unrestricted 270 kg
- Platform Rotator (Hydraulic) 180 Degrees Hydraulic
- Dimensions:
 - A. Platform Size 0.91 m x 1.83 m
 - B. Overall width 2.24 m
 - C. Tailswing (working condition) 0.49 m
 - D. Stowed Height 2.16 m
 - E. Stowed Length 7.57 m
 - G. Ground Clearance n/a
- Machine Weight 6,604 kg
- Max Ground Bearing Pressure 0.3661 kg/cm²
- Drive Speed 2.6 km/h
- Gradeability 51%
- Turning Radius Zero
- Type of tracks Rubber

Reach Diagram

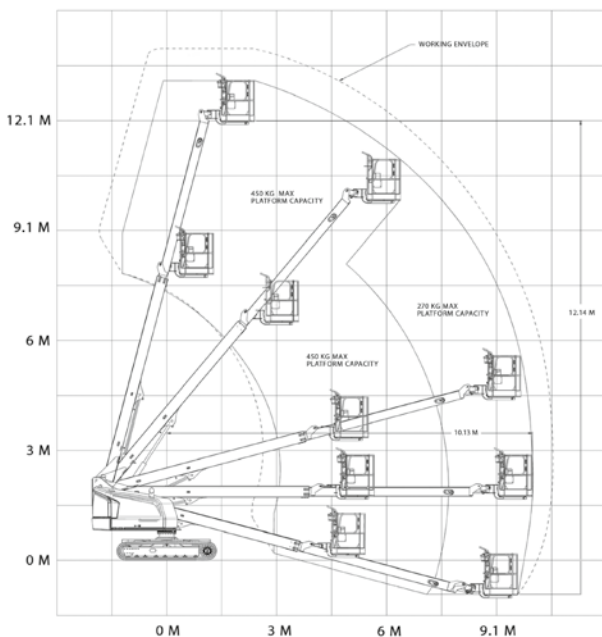

Dimensions

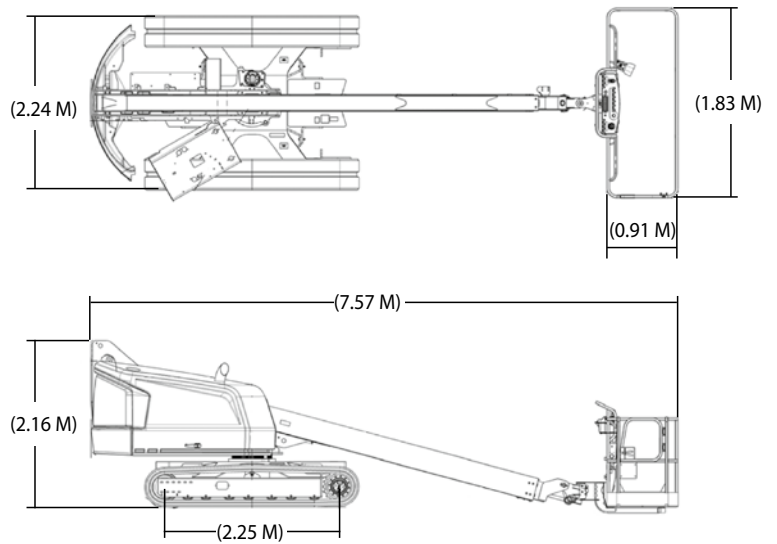

IMPORTANT

JLG is continually researching and developing products and reserves the right to make modifications without prior notice. All data in this document is indicative. Certain options or country standards will increase weight. Specifications may change to meet country standards or with the addition of optional equipment.

Use only JLG approved attachments with proper material handler model/attachment load capacity charts displayed in the operator's cab.

Due to continuous product improvements, JLG Industries reserves the right to make specification and/or equipment changes without prior notification.



JLG EMEA BV

Polaris Avenue 63
2132 JH Hoofddorp
The Netherlands
Tel: +31 (0)23 565 5665
Fax: +31 (0)23 557 3750
www.jlg.com

An Oshkosh Corporation Company